



**Innovative solutions**  
Patents & protective certificates

## Application

CALIDO S40 PRO are antical ball valves intended for installation in drinking water systems, central heating systems (water must comply with norm PN-C-04607:1993), pneumatic and oil systems (these systems must be free from impurities which might cause valve damages) and cooling systems.

## Parameters

- PN = 40 bar (for fluids);
- Tmin = -20°C (without freezing), Tmax = 150°C (for fluids).

## Materials

- materials approved to contact with drinking water and glycol solution up to 40%;
- materials comply with requirements of 4MS system;
- body made of DZR brass resistant to dezincification;
- ball made of CW617N brass, covered with nanoceramics;
- external surface finish - sandblasted brass;
- sealing of the ball, gland nut and stem made of PTFE Teflon;
- lever and lever nut made of stainless steel.

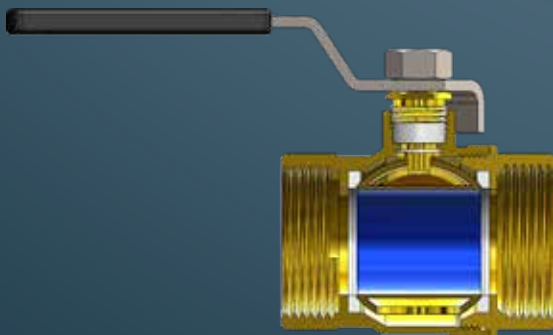

## Features - product advantages

- ball is covered with nanoceramics - **avoidance of limescale deposits disturbing the operation of the valve;**
- valve stem equipped with double sealing:
  - at the top of the stem traditional passive gland is used, with the possibility of additional sealing with a nut;
  - at the bottom of the stem, modern dynamic sealing is applied in which the force of sealing increases with the increase in pressure between the ball and the body - **leakproofness guarantee;**
- increased wall cross-sections in sensitive areas and added four reinforcing bridges on the circumference of the body - **guarantee of valve durability and long life service;**
- design and assembly of the stem prevent it from being pushed out of the body - **guarantee of safety;**
- chamfered beginning of the thread - **to facilitate guiding of both the screwed - in element on the thread and the formation of sealants between the threads;**
- valve equipped with stainless steel lever and cover plate made of material - **guarantee of long life service of the lever;**
- handle cover plate with window and label - **possibility of description, e.g. to which fixture we may close the flow with particular valve;**
- design of body and lever facilitates the change of lever mounting sides - **to make it easier when mounting the valve.**

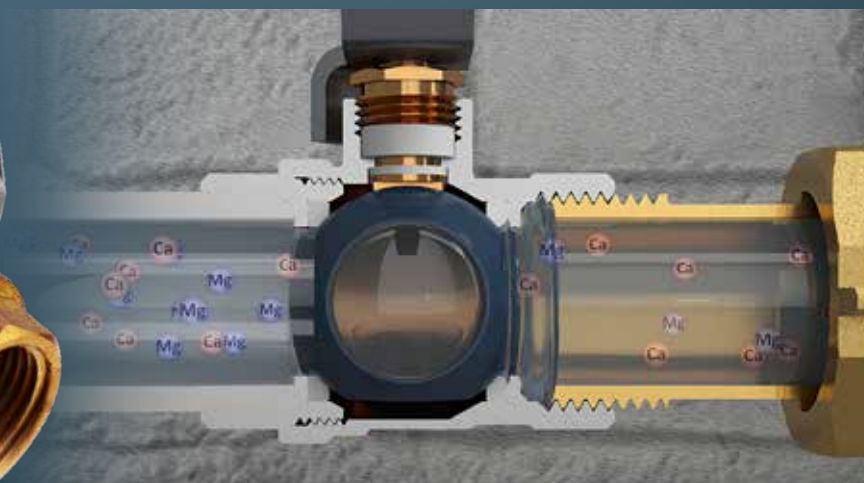

Ball is covered with nanoceramics - avoidance of limescale deposits disturbing the operation of the valve.



## Application

CALIDO S30 ball valves are intended for installation in central heating systems (water must comply with norm PN-C-04607:1993), drinking water systems, pneumatic and oil systems (these systems must be free from impurities which might cause valve damages) and cooling systems.

## Parameters

- PN = 30 bar (for fluids);
- Tmin = -20°C (without freezing), Tmax = 150°C (for fluids);  
Tmax = 110°C (for fluids for valves with half-union).

## Materials

- materials approved for contact with drinking water and glycol solution up to 40%;
- valve body, ball and stem made of CW617N brass;
- external surface finish - nickel;
- sealing of the ball, gland nut and stem made of PTFE Teflon;
- lever and lever nut made of steel covered with anti-corrosion coating GEOMET.

## Features - product advantages

- valve stem equipped with double sealing:
  - at the top of the stem traditional passive gland is used with the possibility of additional sealing with a nut;
  - at the bottom of the stem, modern dynamic sealing is applied in which the force of sealing increases with the increase in pressure between the ball and the body - **leakproofness guarantee**;
- increased wall cross-sections in sensitive areas and added four reinforcing bridges on the circumference of the body - **guarantee of valve durability and long life service**;
- design and assembly of the stem prevent it from being pushed out of the body - **safety guarantee**;
- chamfered beginning of the thread - **to facilitate guiding of both the screwed-in element on the thread and the formation of sealants between the threads**;
- valve equipped with lever covered with anti-corrosion GEOMET cover and plate made of material. Optionally the valve is available with powder - coated "butterfly" aluminium lever - **guarantee of long life service of lever/butterfly**;
- handle cover plate with window and label - **possibility of description, e.g. to which fixture we may close the flow with particular valve**;
- design of body and lever facilitates the change of the lever mounting sides - **to make it easier when mounting the valve**.

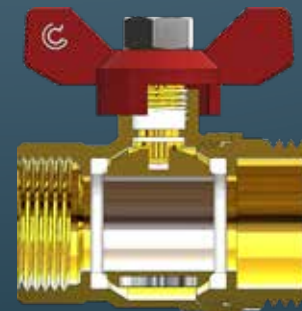

National Technical Assessment – KOT – 2020/1313 edition 1.  
Valves compliant with the requirements of the European Union Directive 2014/68/EU.

CE certificate for valves sizes 1 1/2" – 4".

Valves compliant with PN-EN 13828:2005 norm (confirmed by research at the Technical University of Koszalin).  
Product with Hygienic Certificate of National Health Institute (brass parts which have contact with water are not covered with nickel).



## Pressure increase - sealing power increase

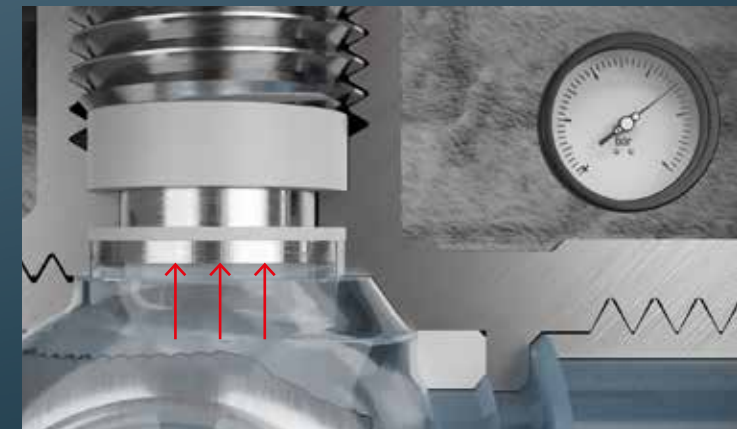

## Application

CALIDO valves OGRÓD and OGRÓD BIS series are intended for installation in water supply systems both inside and outside the buildings.

## Parameters

- PN = 30 bar;
- Tmax = 90°C.

## Materials

- body, ball and stem made of CW617N brass;
- external surface finish - nickel;
- balls sealing made of NBR;
- lever and lever nut made of stainless steel.



## Features - product advantages

- specially designed NBR ball sealing and additional holes in the ball for relief of the pressure in the body by moving back freezing water towards the system - **frost resistant design of the valve;**
- bodies forged as one piece from CW617N brass - **guarantee of leakproofness, durability and long life service of the valve;**
- flow regulator installed inside the body - **guarantee of uniform water jet even after unscrewing hose connection;**
- lever and lever nut made of stainless steel - **guarantee of durability and long life service of the lever;**
- two independent outlets in OGRÓD BIS valves - **possibility of independent opening / closing of these two outlets.**

Valves compliant with the requirements of the European Union Directive 2014/68/EU.

Products with Hygienic Certificate of National Health Institute (brass parts which have contact with water are not covered with nickel).





## Application

Supply and return CALIDO valves ESKIMOS series are intended to control the amount of heating medium supplying the radiator. Due to split stem of supply and return valves it is possible to disconnect the radiator from the installation without having to drain the water.

## Parameters

- PN = 16 bar;
- Tmax = 110°C;
- Kv = 2,4 m<sup>3</sup>/h (straight);
- Kv = 2,8 m<sup>3</sup>/h (angle).

## Materials

- body, stem, cap, nipple and nut made of CW617N brass;
- external surface finish - nickel;
- o-rings made of EPDM;
- knob made of polished ABS.

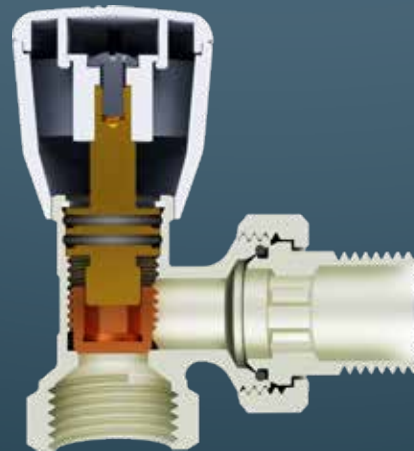

Valves compliant with the requirements of the European Union Directive 2014/68/EU and PN-M-75002:2016-10 norm.

## Features - product advantages

- split valve stem - **possibility to exchange o-rings without having to drain water from the installation;**
- spline inside half union - **ease of installation with a hex key or screwdriver;**
- high flow rates - **lower energy consumption by circulation pumps;**
- flow adjustment and cut off in the return valves with 6 mm hex key - **ease and precision of adjustment;**
- half union sealing metal/metal + o-ring - **leakproofness guarantee even in the event of damage of the o-ring;**
- possibility of half union axis deviation in any direction by 5° - **no strain affecting the valve if the pipe is not in the axis with the valve;**
- supply valve knob covered with shrink wrap - **protection against dirt until the building is put into operation;**
- body forged from one element of CW617N brass - **guarantee of valve leakproofness, durability and long life service;**
- same assembly length of supply and return valves - **easy installation.**

## Manual o-rings replacement without draining the water from the installation:

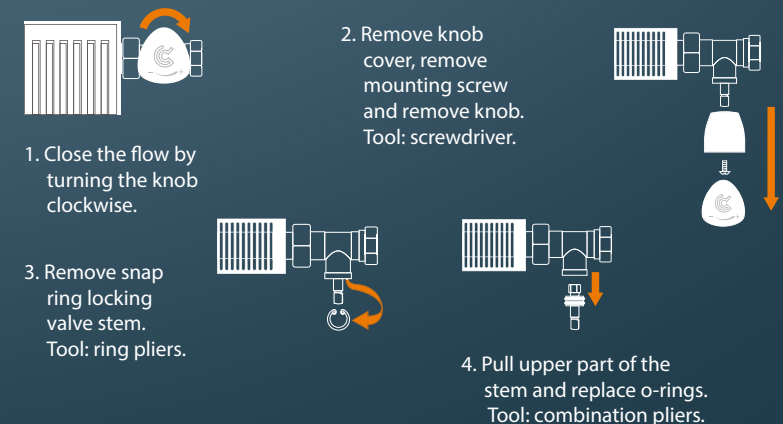

## Application

CALIDO ESKIMOS radiator bottom connectors are intended to adjust or to cut off heating medium flow supplying the radiator. Due to split stem of the connectors it is possible to disconnect the radiator from the installation without having to drain the water.

## Parameters

- PN = 16 bar;
- Tmax = 110°C;
- Kv = 2,4 m<sup>3</sup>/h (straight);
- Kv = 2,8 m<sup>3</sup>/h (angle).

## Materials

- body, stem, cap, nipple and nut made of CW617N brass;
- external surface finish - nickel;
- o-rings made of EPDM.

## Features - product advantages

- split valve stem - **possibility to exchange the o-rings without having to drain the water from the installation;**
- no bridge connecting valves - **possibility of individual valves setting in relation to supply and return pipes;**
- high flow rates - **lower energy consumption by circulation pumps;**
- flow adjustment and cut off with 6 mm hex key - **ease and precision of adjustment;**
- body forged from one element of European CW617N brass - **guarantee of valve leakproofness, durability and long life service;**
- 1/2"x 3/4" nipples included - **ready for assembly.**

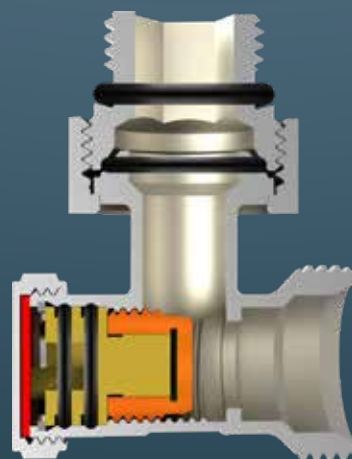

## Manual o-rings replacement without draining the water from the installation:

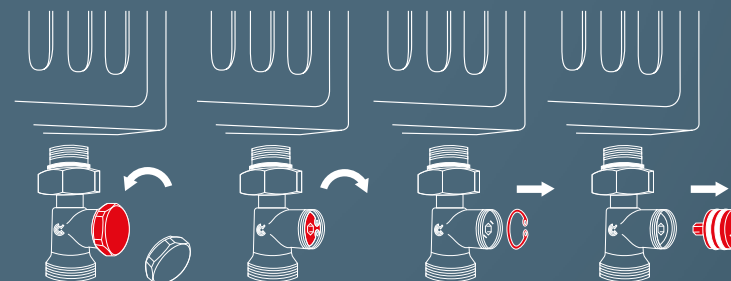

1. Unscrew valve cap by turning anticlockwise.
2. Close the flow by turning stem clockwise. Tool: 6mm hex key.
3. Remove snap ring locking valve stem. Tool: ring pliers.
4. Pull upper part of the stem and replace o-rings. Tool: combination pliers.

When removing the upper part of the stem, only as much water will leak from the radiator as it is left above the valve.

Valves compliant with the requirements of the European Union Directive 2014/68/EU and PN-M-75002:2016-10 norm.

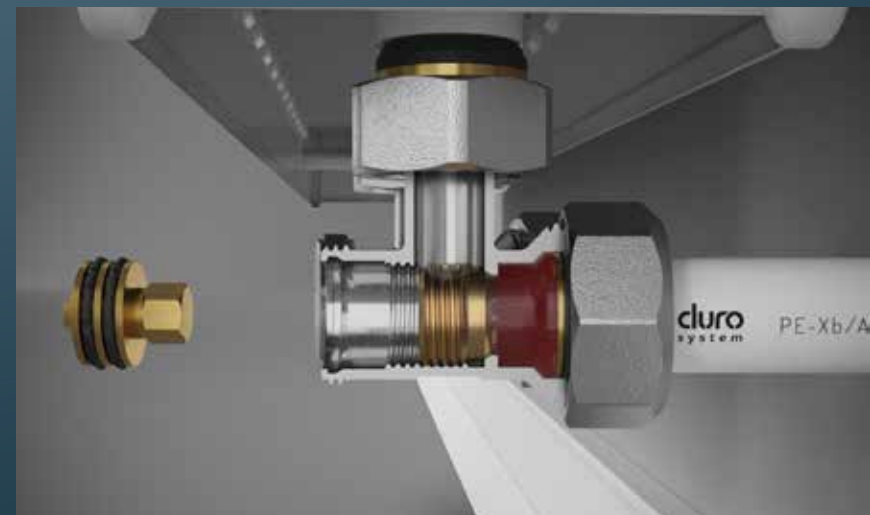

## Application

CALIDO PIONIER disk check valves are intended for installation in drinking and hot water, central and floor heating systems. Their mission is to prevent from the return flows.

## Parameters

- PN = 25 bar;
- Tmin = -20°C (without freezing);
- Operating temp. = 90°C;
- Instantaneous Tmax = 110°C.

## Materials

- body made of sandblasted CW617N brass;
- valve plug, plug guides and closing disc made of POM (antical material);
- sealing plug made of cross-linked EPDM;
- valve spring made of 1.4310 stainless steel.

## Features - product advantages

- unique design of the valve and optimal process of liquid flow obtained as a result of cooperation with Technical University of Koszalin allowed to obtain full - flow characteristics ( $K_v=8,21 \text{ m}^3/\text{h}$  for the 1" valve) - **lower power consumption by circulation pumps;**
- elimination of turbulence within the valve in combination with appropriate selection of materials used for the construction of internal components - **avoidance of formation of limescale disturbing the operation of the valve;**
- special shape of the unit: valve seat, closing disc, seal - **guarantee of quiet valve operation;**
- specially designed valve spring - **compliance with electronic pumps even in night mode reduced - performance;**
- valve can operate both in horizontal and vertical position - **ease of installation.**

Valves compliant with PN-M-75002:2016-10 norm.  
Product with Hygienic Certificate of National Health Institute.

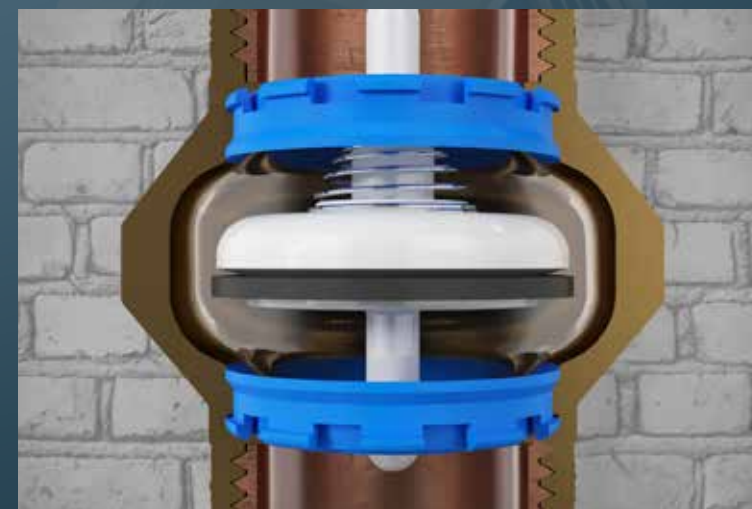
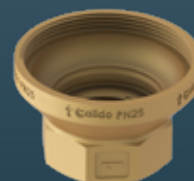
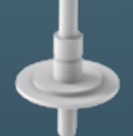



## Application

CALIDO ERYK series are ball valves intended for installation in central heating and drinking water systems. Especially recommended for the connection of wall-mounted dual-function boilers.

## Parameters

- PN = 10 bar;
- Pmax = 16 bar;
- Tnom = 110°C;
- Instantaneous Tmax = 150°C (for valves without non-return valves);
- Instantaneous Tmax = 120°C (for valves with non-return valve).

## Materials

- ball and stem made of CW617N brass;
- body made of DZR brass resistant to dezincification;
- sealing of the ball, gland nut and stem made of PTFE Teflon;
- lever made of aluminium alloy covered with a protective coating;
- filter in 1/2" valve for domestic hot water and central heating systems and 3/4" valve for central heating systems made of POM (antical material);
- non-return valve made of CW617N brass;
- sealing made of EPDM.

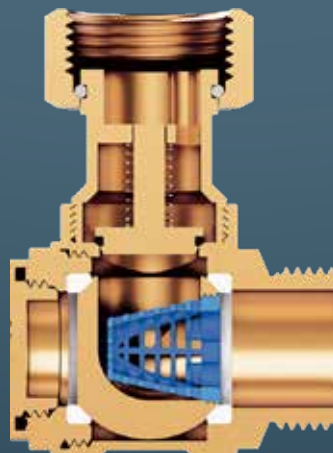

## Features - product advantages

- compact design taking into account limited mounting space of wall-mounted boilers - **easy connection of wall-mounted boilers;**
- 1/2" valve for domestic hot water and central heating systems and 3/4" valve for central heating systems equipped with filter and non-return valve - **solving the problem of installation in limited installation space of wall-mounted boiler when connecting valve, filter and non-return valve (3 in 1) - patent for invention;**
- Kv flow rate ensuring compatibility with boilers of up to 28kW;
- valve stem with double sealing:
  - at the top of the stem traditional passive gland nut is used, with the possibility for additional sealing with a nut;
  - at the bottom of the stem modern dynamic sealing is applied in which the force of sealing increases with the increase in pressure between the ball and the body - **leakproofness guarantee.**
- design and assembly of stem secure it against being pushed out of the body - **safety guarantee;**
- 1/2" valve for domestic hot water and central heating systems and 3/4" valve for central heating systems equipped with anti-calc filter installed in the ball - **boiler protection against contamination from the system and prevention of limescale formation on the filter;**
- 1/2" valve for domestic hot water and central heating systems and 3/4" valve for central heating systems equipped with a non-return valve - **enabling cleaning of the filter without having to drain the system on the boiler side;**
- valve equipped with a lever of aluminium alloy with a protective coating - **guarantee of long life service of the lever;**
- design of lever allows for the use of 10 or 21 mm wrench - **opening/closing of the valves in limited space.**



Valves compliant with the requirements of PN-M-75002:2016-10 norm. Product with Hygienic Certificate of National Health Institute.



## Application

Due to application of two outlets in CALIDO MULTI valve it is possible to connect simultaneously two appliances, for example tap and washing machine/dishwasher and to independently open/close their flows.

## Parameters

- PN = 10 bar;
- Tmax = 95°C.

## Materials

- body made of CW617N brass;
- external surface finishing - chromed, polished;
- ball and stem made of POM (anti-calc material);
- knob made of ABS - chromed, polished;
- screw fixing the knob made of stainless steel;
- o-rings made of EPDM.



Valve compliant with PN-M-75002:2016-10 norm.  
Product with Hygienic Certificate of National Health Institute  
(brass parts which have contact with water are not covered with chrome).



## Features - product advantages

- four settings of the knob - **valve can be set in the following positions: open - open, closed - open, closed - closed or open - closed;**
- body forged as one element of CW617N brass - **guarantee of leakproofness, durability and long life service of the valve;**
- double o-rings of the stem - **guarantee of leakproofness;**
- internal element of the valve made in anti-calc technology - **no limescale accumulation interrupting operation of the valve;**
- two outlets - **tap and washing machine/dishwasher can be connected at the same time;**
- interchangeable adapter 3/8"x3/4" - **valve can operate as „right” or „left”.**

## Four knob settings

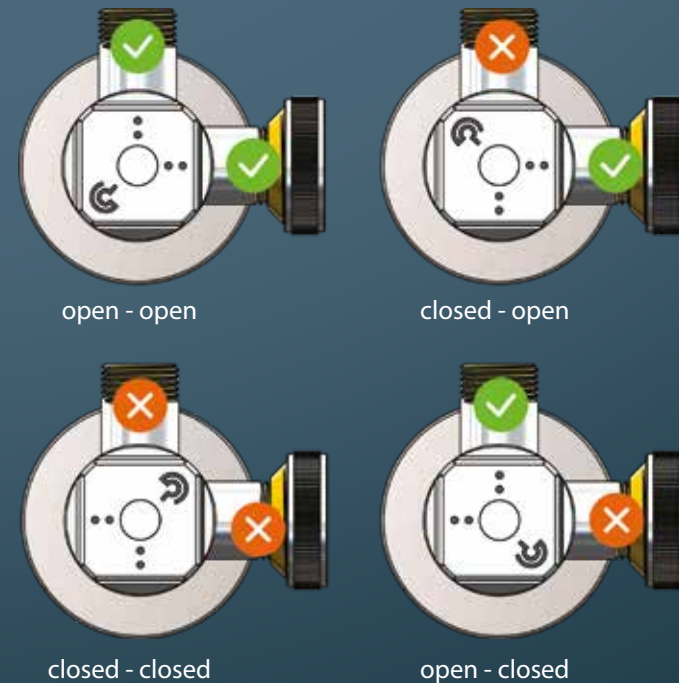

## Application

SOLID and ART angle valves series are intended for installation in water supply systems.

## Parameters

- PN = 16 bar;
- Tmax = 100°C.

## Materials

- body made of CW617N brass, sandblasted, chromed (SOLID series);
- body made of CW617N brass, chromed and polished (ART series);
- valve filter made of POM (anti-calc material);
- ceramic closing system;
- valve stem made of nylon;
- knob made of Zamak, sandblasted, chromed (SOLID series);
- knob made of ABS, polished and chromed (ART series);
- screw fixing the knob made of stainless steel (SOLID series).

## Features - product advantages

- body forged as one element of CW617N brass - **guarantee of leakproofness, durability and long life service of the valve;**
- triple stem o-rings - **guarantee of leakproofness;**
- entire series equipped with anti-calc filter as standard - **protection of supplied devices;**
- internal element of the valve made in anti-calc technology - **no limescale accumulation interrupting operation of the valve;**
- ceramic head with large flow characteristics - **no noises in the system;**
- two outlets in Solid Bis, Solid Bis Pionowy and Art Bis valves - **tap and washing machine/dishwasher can be connected at the same time;**
- interchangeable adapter 3/8"x3/4" in Solid Bis and Art Bis - **valves can operate as „right” or „left”.**



Solid  
1/2"x3/8"  
1/2"x1/2"  
1/2"x3/4"



Solid Bis  
1/2"x3/4"x3/8"



Solid Bis Pionowy  
1/2"x3/4"x3/8"



Art  
1/2"x3/8"  
1/2"x1/2"  
1/2"x3/4"



Art Bis  
1/2"x3/4"x3/8"

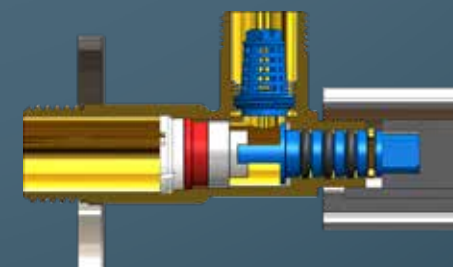

Valves compliant with the requirements of the European Union Directive 2014/68/EU. Products with Hygienic Certificate of National Health Institute (brass parts which have contact with water are not covered with chrome).



## Application

CIRCULA MERCURIO electronic pumps are widely used in central heating systems, air conditioning systems, solar thermal systems and heat pumps.



## Parameters

- fluid temperature from -10°C (without freezing) to 110°C;
- acceptable operating pressure: 10 bar;
- acceptable ambient temperature: 40°C;
- circulated fluid: heating water according to VDI 2035 and water-glycol at 1:1 ratio;
- supply voltage: 230 V (50 Hz);
- protection class: IP44;
- insulation class: F;
- energy efficiency index: EEI ≤ 0.20;
- self-venting design;
- option for additional venting and motor start-up.

## Materials

- body - cast iron;
- motor housing - aluminium;
- rotor - plastic;
- shaft - ceramics;
- bearings - ceramics;
- insulation - biodegradable foam;
- included - two steel half unions with gaskets and electric cable with a plug.

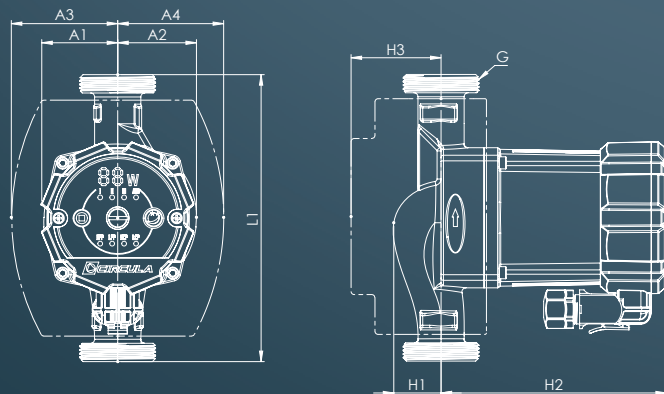

	L1	A1	A2	A3	A4	H1	H2	H3	G
MERCURIO 25/60 130	130	47	49	67	67	30	140	57	1.1/2
MERCURIO 25/40 180	180	47	49	67	67	30	140	57	1.1/2
MERCURIO 25/60 180	180	47	49	67	67	30	140	57	1.1/2

AUTO mode - automatic adjustment of pressure and pump performance to the demand of the installation.

Modes I, II, III - permanent rotational speed.

HPP mode - higher level of proportional characteristics pressure - performance.

LPP mode - lower level of proportional characteristics pressure - performance.

HCP mode - higher level of performance maintaining fixed pump lifting height regardless of performance.

LCP mode - lower level of performance maintaining fixed pump lifting height regardless of performance.

Night mode - after two hours this function was initialised, the pump switches into low performance mode with energy consumption at 5-10W. After seven hours it automatically returns to the mode before the reduction.

The automatic pump venting is achieved by holding down the "night reduction" button for 5 s.

Mercurio pump due to its innovative inspection sleeve in the shaft axis, has an additional venting and emergency rotor start-up features.

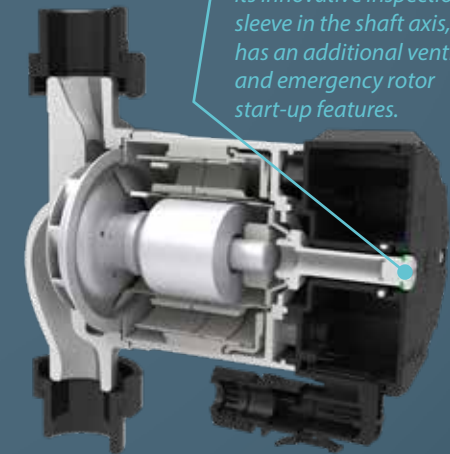

Mercurio 25/40

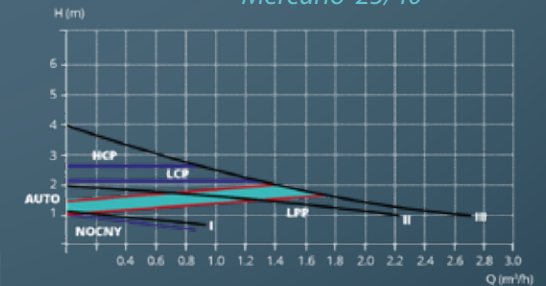

Mercurio 25/60

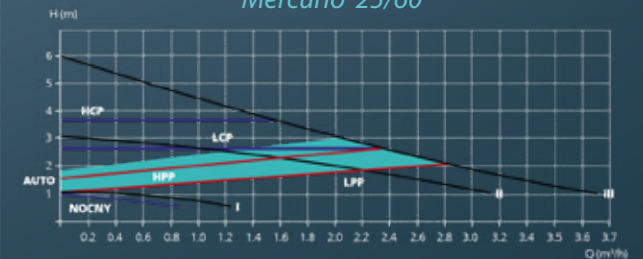



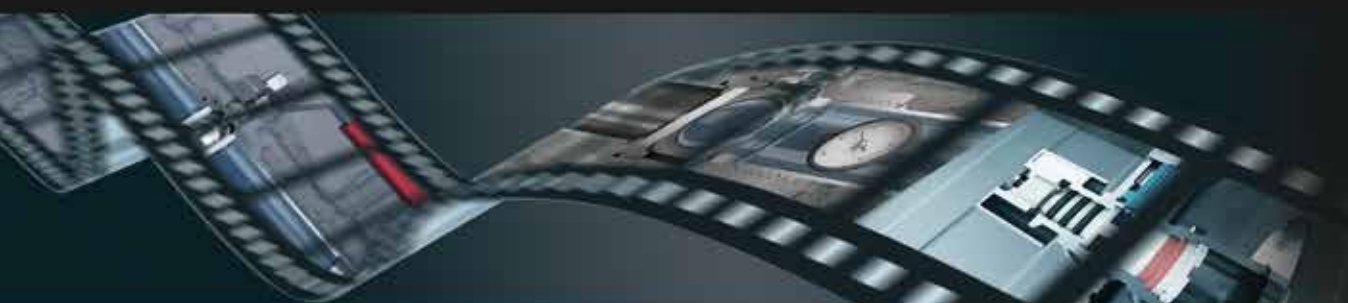

see instructional videos: [arka-instalacje.pl/filmy-x/](https://arka-instalacje.pl/filmy-x/)



Arka Sp. z o.o. sp.k.  
ul. Ogrodowa 5  
76-004 Sianów  
Poland

[arka-instalacje.pl](https://arka-instalacje.pl)