

Stainless steel manifolds

Advantages

- Manifolds made of brushed stainless steel 1.4301 (304)
- 3/4" F connectors with eurocone
- Manifold holders with anti-vibration pads
- Manifolds equipped with a manual air-vent
- Tightness tested 100%
- Resistant to glycol concentration up to 50%
- National Technical Assessment of ITB-KOT 2019/1119 edition 2

In addition the floor heating manifolds are equipped with:

- Rotating drain valves at each manifold
- Flow meters 0÷5 l/min., allowing easy flow regulation in heating circuits
- Control valves with a M30x1,5 connection (for electric actuators) on return manifolds



Central heating manifolds



Manifolds with control valves



Floor heating manifolds

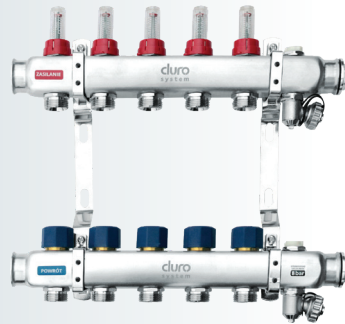

Index	Number of sections	Width (mm)	Height (mm)	Depth (mm)
D/S-RN-CO-2	2	154	290	100
D/S-RN-CO-3	3	204	290	100
D/S-RN-CO-4	4	254	290	100
D/S-RN-CO-5	5	304	290	100
D/S-RN-CO-6	6	354	290	100
D/S-RN-CO-7	7	404	290	100
D/S-RN-CO-8	8	454	290	100
D/S-RN-CO-9	9	504	290	100
D/S-RN-CO-10	10	554	290	100
D/S-RN-CO-11	11	604	290	100
D/S-RN-CO-12	12	654	290	100

Index	Number of sections	Width (mm)	Height (mm)	Depth (mm)
D/S-RN-CO-2	2	204	321	100
D/S-RN-CO-3	3	254	321	100
D/S-RN-CO-4	4	304	321	100
D/S-RN-CO-5	5	354	321	100
D/S-RN-CO-6	6	404	321	100
D/S-RN-CO-7	7	454	321	100
D/S-RN-CO-8	8	504	321	100
D/S-RN-CO-9	9	554	321	100
D/S-RN-CO-10	10	604	321	100
D/S-RN-CO-11	11	654	321	100
D/S-RN-CO-12	12	704	321	100

Index	Number of sections	Width (mm)	Height (mm)	Depth (mm)
D/S-RN-OP-2	2	204	321	100
D/S-RN-OP-3	3	254	321	100
D/S-RN-OP-4	4	304	321	100
D/S-RN-OP-5	5	354	321	100
D/S-RN-OP-6	6	404	321	100
D/S-RN-OP-7	7	454	321	100
D/S-RN-OP-8	8	504	321	100
D/S-RN-OP-9	9	554	321	100
D/S-RN-OP-10	10	604	321	100
D/S-RN-OP-11	11	654	321	100
D/S-RN-OP-12	12	704	321	100

Arka Sp. z o.o.
ul. Ogrodowa 5, 76-004 Sianów
Poland

tel. +48 94 341 77 19
fax: +48 94 346 27 68
arka-instalacje.pl

NEW

D/S-RN-OP-13	13	754	350	100
D/S-RN-OP-14	14	804	350	100
D/S-RN-OP-15	15	854	350	100
D/S-RN-OP-16	16	904	350	100

cluro
system

We create heat

Multilayer pipes

PE-Xb/AL/PE-Xb

DN 16 and 20 in insulation 6 mm
in coils 50 m and 100 m
DN 25 and 26 in insulation 9 mm
in coils 25 m

- The highest cross-linking degree of the multi-layer composite pipes (PE-Xb - min. 65% cross-linked).
- T operation=95°C, T max. momentary =110°C, P max=10 bar.
- Aluminium core, butt welded.
- Available pipe diameters without insulation: 16x2, 20x2, 25x2,5, 26x3, 32x3.
- Certified by AENOR Institute in Spain
- 15 year guarantee

PE-RT/AL/PE-RT

DN 16 in insulation 6 mm in coils 100 m
→ T max=90°C,
→ Tmal=100°C/100h, Pmax=6 bar.
→ Aluminium core, butt welded.
→ PE-RT type I.
→ Certified by AENOR Institute in Spain
→ 15 year guarantee

PE-RT/EVOH/PE-RT

DN 16 coils 240 m, 500 m and 600 m
→ T max=70°C, To=60°C, Pmax=6 bar.
→ PE-RT type II.
→ Oxygen diffusion barrier
→ 10 year guarantee



Press fittings

- European brass with increased mechanical resistance and resistance to corrosion
- Double O-rings from cross-linked EPDM – increased resistance to overheating up to 110°C and increased resistance to ageing and cracking
- Multi-profiled fitting. Recommended jaw profiles: TH and H for all pipe diameters and U profiles for DN 16 and DN 20 pipes
- Sleeves made from stainless steel AISI304, resistant to corrosive compounds included in cement
- Press fittings have been approved by the NIZP-PZH

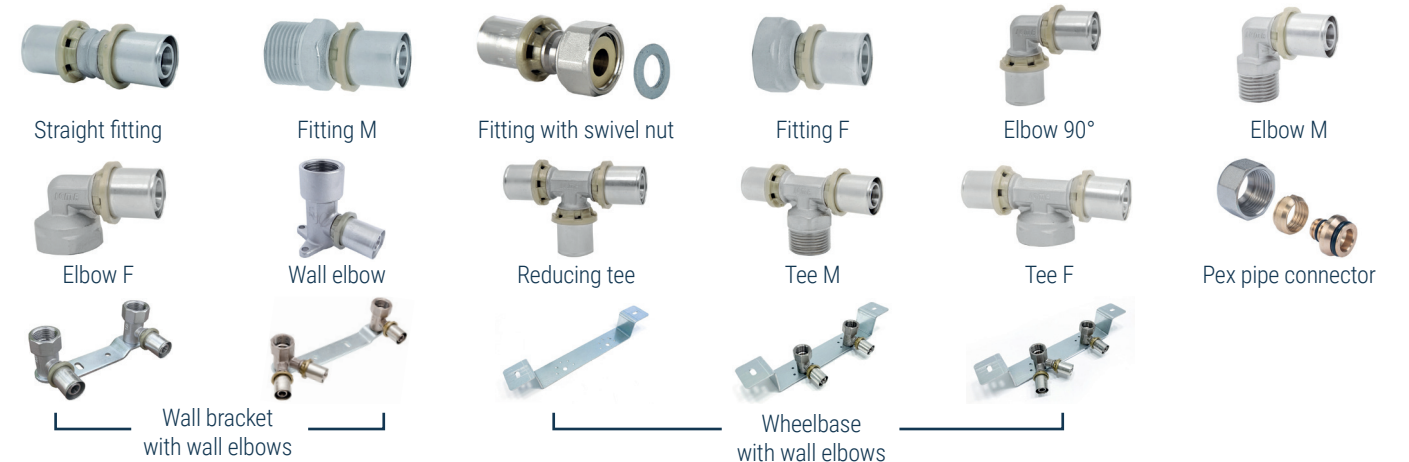

Compression fittings

- Double o-rings from cross-linked EPDM – increased resistance to overheating up to 110°C and increased resistance to ageing and cracking
- Compression fittings have been approved by the NIZP-PZH



Mixing systems for floor heating manifolds

The mixing system is intended for assembly in heating installations,

where a reduction of the heating medium temperature is required to the set appropriate level (in the range of 23÷43°C), e.g. for heating floor or wall. A mixing system may be used with manifolds spacing between the upper and lower collector, equal to 210 mm and with the number of 2 to 16 heating circuits. It has the National Technical Assessment ITB-KOT 2019/1119 edition 2.

Technical data:

- Maximum static pressure: **10 bar**
- Maximum working temperature: **90°C**
- Thermostatic valve temperature adjustment range: **23÷43°C**
- Regulation accuracy of the thermostatic valve: **2°C**
- Kv: **1.6 m³/h**
- Maximum heating area: **125 m²**
- Acceptable media: **non-aggressive water in accordance with PN-EN 12952-12:2006 and glycol concentration up to 50%**

Construction and dimensions:

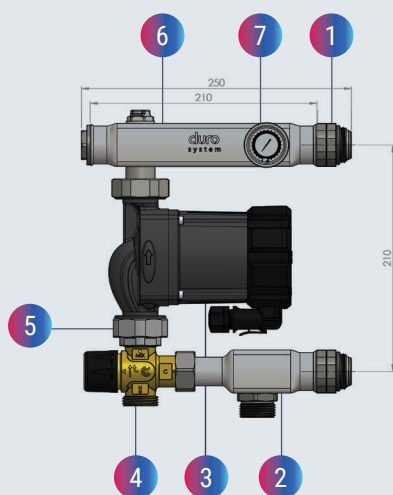

- ① Double sided connector
- ② Lower collector
- ③ Electronic pump (optional)
- ④ Three-way thermostatic mixing valve Calido
- ⑤ Half union 1 x 1 1/2
- ⑥ Upper collector
- ⑦ Thermometer

Flow diagram:

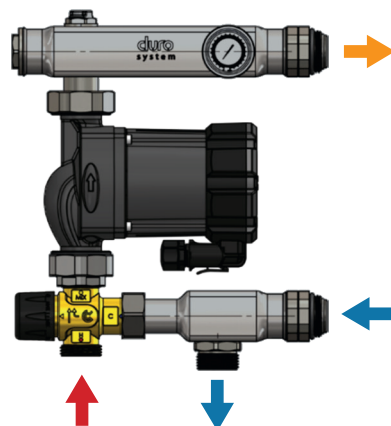

Available variants:

- **D/S-UMN-A-B/POMPY** - mixing system without a pump, with Calido three-way thermostatic mixing valve.
- **D/S-UMN-A-MERC 25/60** - mixing system with a pump Circula Mercurio 25/60-130 mm with plug and cable, with three-way thermostatic mixing valve Calido.
- **D/S-UMN-A-HELIO 25/60** mixing system with Circula Helio electronic pump 25/60-130 mm with plug, with three-way thermostatic valve mixing Calido.
- **D/S-UMN-A-TITAN 25/60** - mixing system with Circula Titanio 25/60-130 mm electronic pump with power cord, with three-way thermostatic valve mixing Calido.

Dual-purpose mixing systems for floor heating and central heating manifolds

The dual-purpose mixing system is designed for installation in water heating systems.

The design of the system enables the connection of the power supply elements of the system in one set surface and radiator heating. The dual-purpose mixer combines two types of installation: high-temperature installation (e.g. radiator) and surface heating installation, where it is required to reduce the temperature of the heating medium to the set level (in the range of 20÷43°C). A mixing system may be used with manifolds with a spacing of the supply manifold beam axes and return of 210 mm. It has the National Technical Assessment ITB-KOT 2019/1119 edition 2.

Technical data:

- Maximum Static Pressure: **10 bars**
- Maximum working temperature: **90°C**
- Thermostatic valve temperature adjustment range: **20÷43°C**
- Adjustment Accuracy: **± 4°C**
- Kv of the thermostatic valve: **3.2 m³/h**
- Maximum number of surface heating circuits *: **10 circuits**
- Maximum number of radiators *: **10 radiators**
- Acceptable media: **non-aggressive water according to PN-C-04607:1993 and glycol concentration up to 50%**

* the number of surface heating circuits and radiators should be selected at the installation design stage, taking into account the hydraulic parameters of the installation and system mixing and the power of the power source.

Flow diagram:

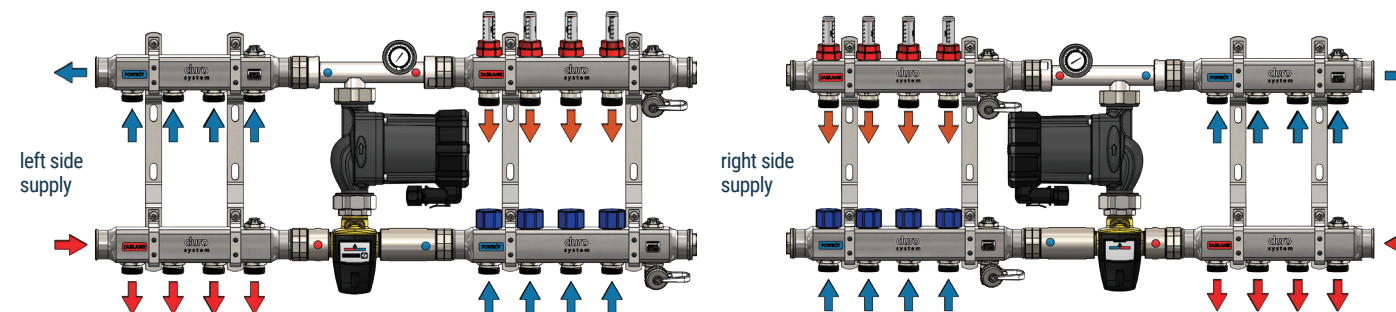

Available variants:

- **D/S-UMND-B/POMPY**
Dual-purpose mixing system without a pump, with three-way thermostatic mixing valve ESBE 552.
- **D/S-UMND-MERC**
Dual-purpose mixing system with a pump electronic Mercurio 25/60-130 mm, with three-way thermostatic mixing valve ESBE 552.



Construction and dimensions:

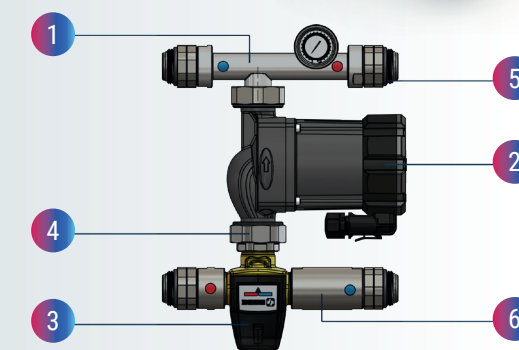

- ① Upper collector
- ② Electronic pump (optional)
- ③ ESBE thermostatic valve
- ④ Pump half union 1 x 1 1/2
- ⑤ Double sided connector
- ⑥ Lower collector