

 **CIRCULA**



Electronic circulation pump

TITANIO

Manual

CONTENTS

| | | |
|-----|--|----|
| 1. | Introduction | 5 |
| 2. | Types and dimensions | 5 |
| | 2.1 Model overview | 5 |
| | 2.2 Dimensions | 6 |
| 3. | Safety rules | 7 |
| 4. | Purpose and installation | 8 |
| | 4.1 Pumped liquids | 8 |
| | 4.2 Liquid temperature and ambient temperature | 9 |
| | 4.3 Instalacja | 10 |
| | 4.4 Positions of the control box | 11 |
| | 4.5 Electrical connection and PWM signal | 11 |
| 5. | Characteristics and operation of the pump..... | 12 |
| | 5.1 Control panel - description | 12 |
| | 5.2 Automatic pump venting function | 14 |
| | 5.3 Pump start function | 14 |
| | 5.4 Hydraulic characteristics of pumps | 15 |
| | 5.5 PWM | 16 |
| | 5.5.1 Control principles | 16 |
| | 5.5.2 PWM input signal | 17 |
| | 5.5.3 PWM signals | 18 |
| | 5.5.4 PWM feedback signal (power consumption) | 19 |
| | 5.5.5 PWM feedback signal | 20 |
| 6. | Technical data | 20 |
| 7. | Problems and solutions | 21 |
| 8. | Warranty card | 22 |
| 9. | Post-warranty service | 22 |
| 10. | Declaration of Conformity | 23 |

WARNINGS

Please read the following notes before starting installation and use of the pump.

- ! Before starting the pump, always make sure that the installation is filled with water and do not allow the pump to run dry. Do not tighten or loosen the pump fittings and head mounting screws pressurized pumps.
- ! The pump should be installed by qualified personnel in compliance with this operating and installation manual and with the principles of good practice installation. The manufacturer is not responsible for any damage caused improper pump installation.
- ! During pump operation, high temperatures of the heating medium exist risk of burns upon contact with the pump body.
- ! In the event of leaks from installations that may threaten electronic systems pump, disconnect it immediately.
- ! Be careful when servicing the electronic pump.



HOW TO DISPOSAL OF USED EQUIPMENT

This pump is marked in accordance with European Directive 2012/19/EU and Polish Act of September 11, 2015 „On waste electrical and electronic equipment” (Journal of Laws of October 23, 2015, item 11688) with the crossed-out container symbol for waste. This marking means that this equipment has reached the end of its useful life it cannot be placed together with other waste from the farm household. The user is obliged to hand it over to the person conducting the collection waste electrical and electronic equipment. Doing the right thing with waste electrical and electronic equipment contributes to avoidance consequences that are harmful to human health and the natural environment due to the presence of hazardous ingredients and improper storage and processing of such equipment.

1. Introduction

In the electronic circulation pump, the stator of the motor is completely enclosed and rotating parts are immersed in clean water, which plays an important role in cooling and lubrication during operation. The pump cover sleeve has a thin structure walls to completely shield the motor stator from water. Traditional design mechanical seal is eliminated and the problem of conventional leakage the water pump is solved. Rotating elements are made of ceramic wear-resistant bearings and ceramic rotating shafts and lubricated with pure water, they can cool the engine and reduce noise. The pump will not overload when operating at full capacity. In principle, the pump can be maintenance-free, provided it is used correctly.

2. Types and dimensions

2.1 Model overview

Model designation:

CI-TITANIO 25 / 40 - 180

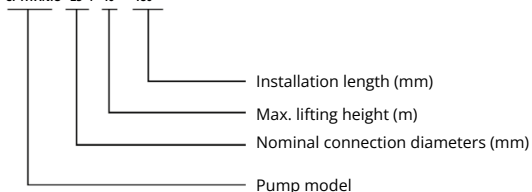

| Model | Diameter nominal connections | Size connections | Flow maximum | Height lifting | Tension | Frequency | Power | Current | EEI |
|----------------------|------------------------------|------------------|-------------------|----------------|---------|-----------|-------|---------|--------|
| | mm | | m ³ /h | m | | | | | |
| CI-TITANIO 15/60-130 | 15 | G 1" | 3,2 | 1 - 6 | 230 | 50 | 45 | 0,5 | ≤0,20* |
| CI-TITANIO 25/40-180 | 25 | G 1 1/2" | 2,5 | 0,7 - 4 | | | 25 | 0,3 | ≤0,20* |
| CI-TITANIO 25/60-130 | 25 | G 1 1/2" | 3,2 | 1 - 6 | | | 45 | 0,5 | ≤0,20* |
| CI-TITANIO 25/60-180 | 25 | G 1 1/2" | 3,2 | 1 - 6 | | | 45 | 0,5 | ≤0,20* |
| CI-TITANIO 25/80-130 | 25 | G 1 1/2" | 3,4 | 1,5 - 8 | | | 65 | 0,65 | ≤0,21 |
| CI-TITANIO 25/80-180 | 25 | G 1 1/2" | 3,6 | 1,5 - 8 | | | 65 | 0,65 | ≤0,21 |
| CI-TITANIO 32/80-180 | 32 | G 2" | 4 | 1,5 - 8 | | | 65 | 0,65 | ≤0,21 |

* The benchmark for the most energy-efficient circulation pumps is EEI ≤ 0,20.

2.2 Dimension

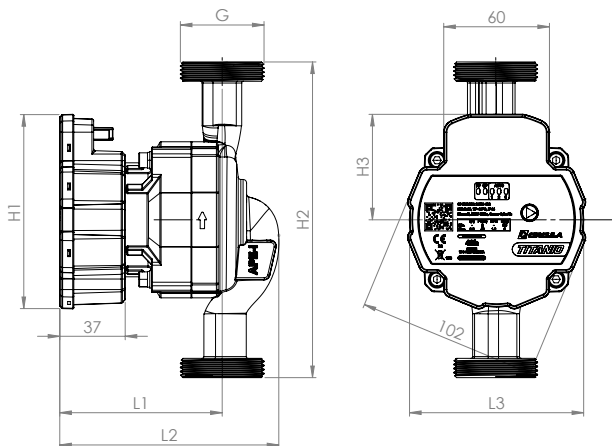

| Model | Dimension (mm) | | | | | | |
|---------------------|----------------|-----|----|-----|----------|----|----------|
| | L1 | L2 | L3 | H1 | H2 | H3 | G |
| CI-TITANIO 15/X-130 | 93 | 126 | 99 | 110 | 130 | 60 | G 1" |
| CI-TITANIO 25/X-130 | | | | | | | G 1 1/2" |
| CI-TITANIO 25/X-180 | | | | | G 1 1/2" | | |
| CI-TITANIO 32/X-180 | | | | | G 2" | | |

3. Safety rules



- Do not touch the pump body while it is running.
- Do not run the pump without water

1. The supply voltage of the electronic pump is single-phase 230V, and the frequency is 50 Hz.
2. Before installation, make sure the pipe system is connected securely and check for impurities, soldering residues and waste have been removed from the pipes.
3. Make sure the pump is in a dry and ventilated environment, to avoid short circuit caused by moisture or splashes in the housing and guarantee its availability for service and replacement.
4. It is recommended to install cut-off valves on the inlet connections and exhaust to enable subsequent service and maintenance pumps.
5. Do not touch the pump and/or other pipes to avoid burns.
6. To avoid accident, please unplug the power before proceeding for any service activities.
7. Check the pump regularly and replace it if any damage.
8. The power cord may only be replaced with appropriate cords or dedicated components.
9. In winter, when the ambient temperature is below 0°C and the pump stops work to avoid pump cracks due to frost, water from the pipes must be thoroughly removed.
10. Heat supply pipes cannot be refilled with water frequently unsoftened to avoid calcium build-up inside the piping system and blocking of the rotor.

4. Intended use and installation

4.1 Pumped liquids

Water in heating installations should comply with PN-C-04607:1993 and be (free from solid particles, fibers and impurities) and water-glycol solution of up to 50% concentration.

Maximum working pressure: 1,0 MPa (10 bar)



To avoid bearing damage pumps should be kept to a minimum pressure of the medium on the suction side pumps.

| | | | |
|---------------------|-----------|----------|----------|
| Liquid temperature | 85°C | 90°C | 110°C |
| Ambient temperature | 5 m | 2,8 m | 11,0 m |
| | 0,049 bar | 0,27 bar | 1,08 bar |



The pump is designed for the following systems:

- non-aggressive, non-explosive liquids, not contaminated with particles
- solids and fibers,
- cooling liquids (without oil additives),
- liquids intended for heating systems.

4.2 Liquid temperature and ambient temperature

The diagram shows a grey pipe with a white and black CIRCULA TITANIO pump attached. A thermometer is inserted into the top of the pipe, labeled 'Liquid temperature (t1)'. Another thermometer is shown to the right, labeled 'Ambient temperature (t2)'. A warning symbol (a hand with a slash) is shown next to the pump body, with an arrow pointing to it. Below the warning is the text: 'Do not touch the surface of the pump body, to avoid burns.'

| | |
|--------------------------|--------|
| Liquid temperature (t1) | 95°C |
| Ambient temperature (t2) | 0-40°C |

4.3 Instalacija

When assembling, the motor shaft must be aligned with the horizontal axis, direction fluid flow in the pipe must be the same as the arrow marked on the body pumps.

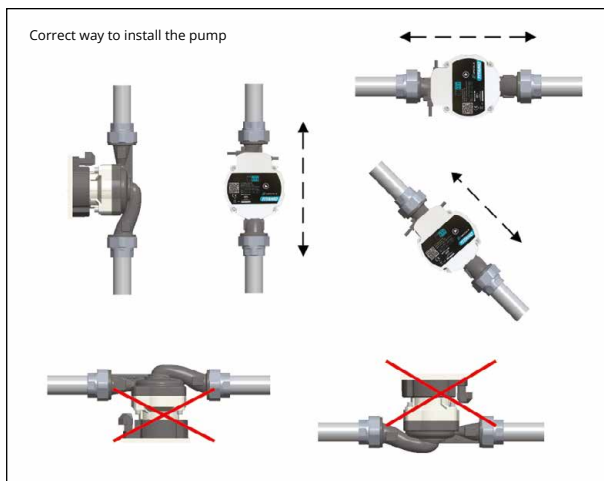
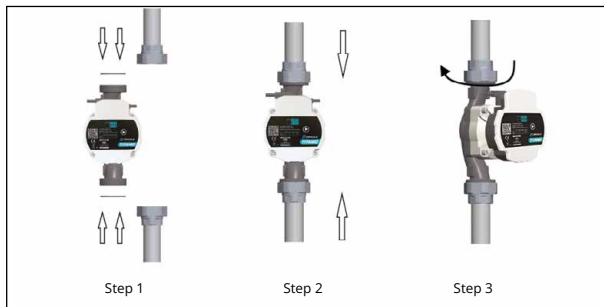

4.4 Positions of the control box

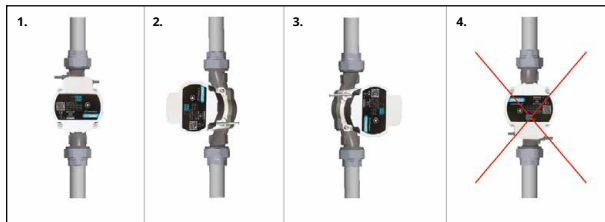

Warning!

Changes in the position of the control box and engine housing may only be performed by an authorized Circula pump service center.

4.5 Electrical connection and PWM signal

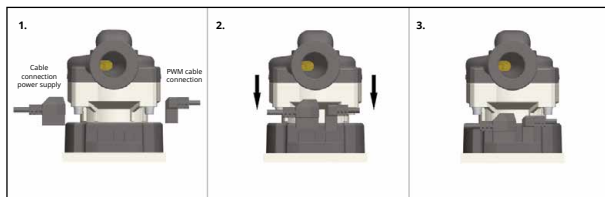





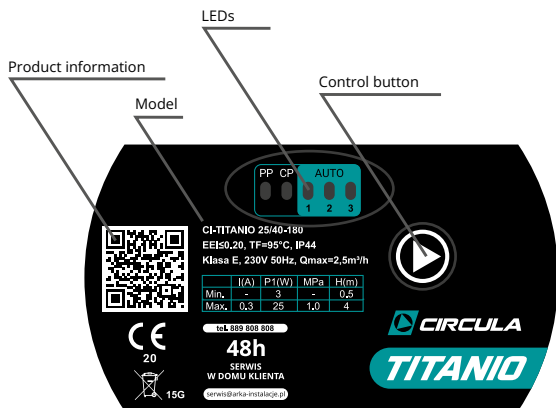







5. Pump characteristics and operation

5.1 Control panel - description



Relationship between the electronic pump setting and the display indications:

| Number of button presses | Mode | Description | Display |
|--------------------------|------------------------------|--|---|
| 0 | CS III (factory settings) | Constant curve, speed III |  |
| 1 | AUTO | Mode adaptive |  |
| 2 | PP I | Proportional curve pressure, speed I |  |
| 3 | PP II | Proportional curve pressure, speed II |  |
| 4 | PP III | Proportional curve pressure, speed III |  |
| 5 | CP I | Constant pressure curve, speed I |  |
| 6 | CP II | Constant pressure curve, speed II |  |
| 7 | CP III | Constant pressure curve, speed III |  |
| 8 | CS I | Constant curve, speed I |  |
| 9 | CS II | Constant curve, speed II |  |
| 10 | CS III | Constant curve, speed III |  |
| / | PWM | External control of motor speed |  |

5.2 Automatic pump venting function

The function is called by holding down the button  for about 5 seconds until the first 3 LEDs light up.



The pump goes into venting mode for 5 minutes: it will run alternately at 1200 rpm, 4500 rpm and 3000 rpm (each is turned on for 3-5 seconds). When automatic bleeding is complete the pump returns to the previously set operating mode.

5.3 Pump start function

In the event of a blocked impeller, e.g. after a long pump standstill, possible is to activate the pump start function. The function is called by holding the button  for about 8 seconds until it lights up all 5 diodes.



The pump enters the rotor start-up mode for 5 minutes, which means cyclical tests starting at 4800 rpm. In case of successful rotor start, the pump returns to the previously set operating mode. But in case of failure start-up of the rotor, the first two indicator LEDs will light up on the pump display protection against jamming of the rotor.



5.4 Hydraulic characteristics of the pumps

CI-TITANIO 25/40

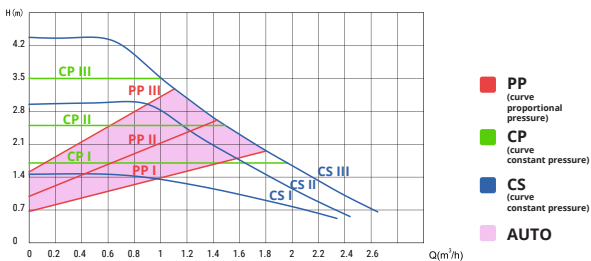

CI-TITANIO 25/60, CI-TITANIO 15/60

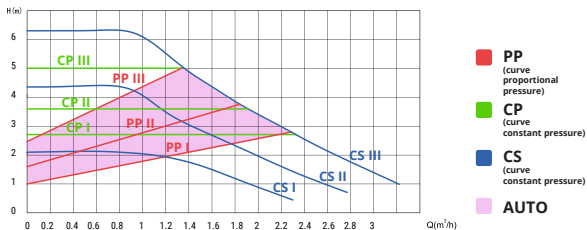

CI-TITANIO 25/80, CI-TITANIO 32/80

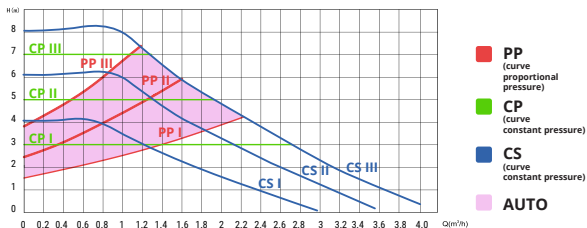

5.5 PWM

5.5.1 Control Principles

When the PWM signal is connected, the operation of the circulation pump is controlled by the PWM signal, and in the absence of the PWM signal, the operation of the circulation pump is controlled by the pump's internal controller.

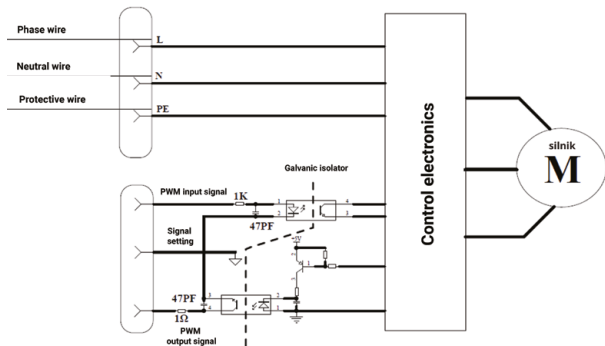

5.5.2 PWM input signal

At high percentages of the PWM signal (duty cycles) hysteresis prevents the circulation pump from starting and stopping if the input signal varies around the switch point. At low values percentage of the PWM signal, for security reasons, the speed of rotation circulation pump is high. In case of cable breakage in the boiler installation gas, the circulation pump will continue to run at maximum speed rotating to transfer the heat from the boiler to the installation.

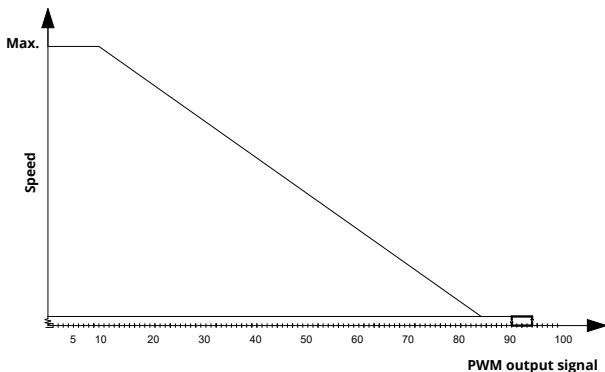

| Input signal PWM (%) | Pump status |
|----------------------------|---|
| 0 | Put the pump in non-PWM mode (internal control) |
| $0 < \text{PWM} \leq 10$ | Maximum speed |
| $10 < \text{PWM} \leq 84$ | Variable speed: max to min. |
| $84 < \text{PWM} \leq 91$ | Minimum speed |
| $91 < \text{PWM} \leq 95$ | Hysteresis area: on / off |
| $95 < \text{PWM} \leq 100$ | Standby: disabled |

5.5.3 PWM signals

| | |
|----------------------------------|---|
| Galvanic isolation in the pump | YES |
| Input frequency | 1000 - 2500 Hz |
| Input voltage (U_{iH} , high) | 4,0 - 5,5 V |
| Input voltage (U_{iL} , low) | < 0,7 V |
| Input current (I_i , high) | Maks. 3,5 mA przy 4700 ohm Maks. 0 mA przy 100 ohm |
| PWM input duty cycle | 0-100% |
| Signal polarity | constant |
| Signal cable length | <3 m |
| Time to rise, fall | <T/1000 |

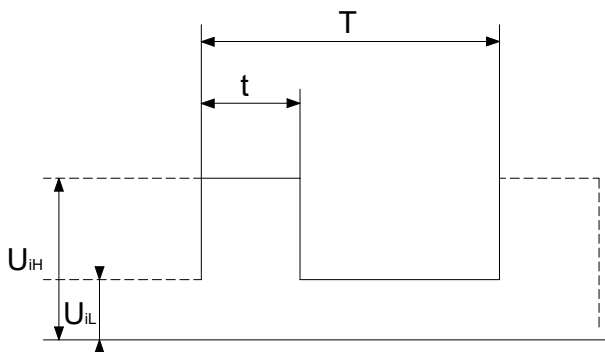

5.5.4 PWM return signal (power consumption)

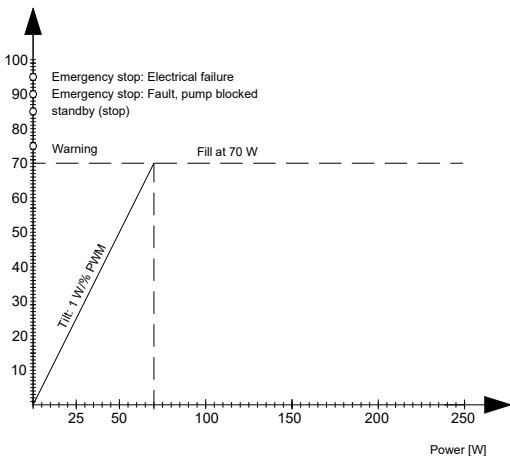

| Signal output (%) | Qualification time (s) | Pump information | DT disqualification time (s) | Priority |
|-------------------|------------------------|------------------------------------|------------------------------|----------|
| 95 | 0 | Standby by PWM signal (STOP) | 0 | 1 |
| 90 | 30 | Alarm stop, interlock | 12 | 2 |
| 85 | 0 - 30 | Emergency stop, electrical failure | 1-12 | 3 |
| 75 | 0 | Warning | 0 | 5 |
| 0-70 | | 0 - 70 W (slope 1W/%PWM) | | 6 |
| Frequency exit | 75 Hz +/- 5% | | | |

5.5.5 Return signal PWM

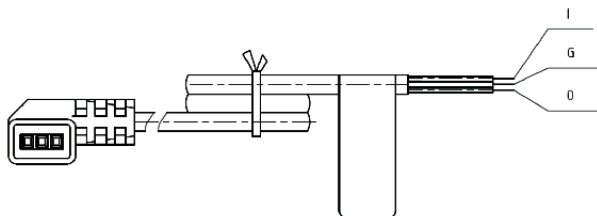

I - red - PWM input (controller)

G - black - ground wire (GND)

O - yellow - PWM output (from the pump)





6. Technical data

| | | | | |
|-----------------------|----------------------|---------|---------------------|----------------------|
| Supply voltage | 230 V, 50 Hz | | | |
| Protection class | IP44 | | | |
| Insulation class | E | | | |
| Installation pressure | Max. 95% | | | |
| Installation pressure | Max. 1,0 MPa, 10 bar | | | |
| Inlet pressure | Liquid temperature | ≤ +75°C | Min. inlet pressure | 0,05 bar , 0,005 MPa |
| | | +90°C | | 0,28 bar , 0,028 MPa |
| | | +110°C | | 1,08 bar , 0,108 MPa |
| Liquid temperature | +2°C~+95°C | | | |

7. Problems and solutions

| Problem | Possible cause | Solution |
|--|---|--|
| The pump is not working | Incorrect connection power cord | Make sure that power cord is connected correctly |
| | power cord | Replace the fuse |
| Installation noise or pump body | Impurities inside pumps, blocked impeller | Disassemble the pump and remove |
| | The flow is set too big | pollution |
| | Air in the system or pump housing | Remove air / vent the pump |
| The pump runs but does not generate any pressure | The inlet valve is closed | Open the valve |
| | Air in the installation | Vent the system and pump |

In the event of a failure, the pump electronics will respond to some of the faults and protect the pump. The following table shows the security codes on the display panel:

| Protection type | Display |
|--|---|
| Protection against blockage of the rotor |  |
| Safeguard overvoltage/undervoltage |  |
| Open phase protection |  |
| Safeguard overcurrent |  |

8. Warranty card

| Pump model | Stamp of the seller | Date of sale / Seller's signature |
|------------|---------------------|-----------------------------------|
| | | |
| | | |

The ARKA company provides a 24-month warranty for the product, counting from the date of its sale, provided that the Buyer complies with the installation, use and maintenance instructions. The warranty covers only manufacturing defects in material and workmanship arising in the process production.

The warranty does not cover:

- mechanical damage,
- damage caused by the installation of the pump not in accordance with the installation instructions or
- unauthorized interference,
- damage caused by improper use or handling of the pump,
- damage caused by the penetration of solid impurities into the interior
- pumps,
- damage caused by freezing, lightning or defects
- installation
- electricity, in particular moisture in electrical connections,
- damage caused by the pump running dry.

The basis for considering a warranty claim by ARKA is the possession of proof purchase and this warranty card.

Complaints are accepted:

- by the point of sale where the product was purchased - in this case, the above
- documents
- must be delivered together with the defective goods,
- electronically: form on the website, "Your Fax number"
- hotline
-
-

(on working days from your hours e.g. 8.00 am to 4.00 pm).

This warranty does not exclude, limit or reduce the buyer's rights arising from it from non-compliance of the goods with the contract.

9. Declaration of Conformity



Deklaracja zgodności UE

nr 2/circula/2020

1. Model produktu:

CIRCULA TITANIO - POMPA ELEKTRONICZNA C.O.

Kod produktu (indeks): CI-TITANIO 25/60-130, CI-TITANIO 15/60-130, CI-TITANIO 25/60-180, CI-TITANIO 25/40-180, CI-TITANIO 25/80-130, CI-TITANIO 25/80-180, CI-TITANIO 32/80-180

2. Nazwa i adres producenta lub jego upoważnionego przedstawiciela:

ARKA Sp. z o.o. sp.k.
ul. Ogrodowa 5
76-004 Ślanów

3. Niniejsza deklaracja zgodności wydana zostaje na wyłączną odpowiedzialność producenta.

4. Zgodność przedmiotu deklaracji potwierdzona certyfikatem:

Certyfikat nr: ISETC.03220200630 wydany przez: ISET Srl Unipersonale
Certyfikat nr: D6 101057 wydany przez: TÜV SÜD Product Service GmbH

5. Wymieniony powyżej przedmiot deklaracji niniejszej deklaracji zgodności UE jest zgodny z odnośnymi wymaganiami unijnego prawodawstwa harmonizacyjnego:

Dyrektywa 2014/35/UE (LVD)
Dyrektywa 2014/30/UE (EMC)
Dyrektywa 2006/42/WE (MD)
Dyrektywa 2009/125/WE (Ekoprojekt)

6. Odniesienia do odnośnych norm zharmonizowanych, które zastosowano, lub do innych specyfikacji technicznych, w stosunku do których deklarowana jest zgodność:

EN ISO 12100:2010
EN 809:1998+A1:2009+AC:2010
EN 60204-1:2018
EN 61000-3-3+A1:2019
EN 60335-1:2012+A11:2014+A13:2017+A1:2019+A14:2019+A2:2019
EN 60335-2-51:2003+A2:2012
EN 62233:2008+AC:2008
EN 60034-1:2010+AC:2010
EN 55014-1:2017
EN 55014-2:2015
EN IEC 61000-3-2:2019

Ślanów, 13 września 2021 r.

(miejsce i data wystawienia)

Arka Sp. z o.o. Sp. k.
Tomasz Borkowski
Kierownik Działu Technicznego (podpis osoby upoważnionej)

Arka Sp. z o.o. Sp. k.
76-004 Ślanów, ul. Ogrodowa 5
Regon 330967270, NIP 669-22-24-025
arka-instalacje.pl

A large, abstract graphic composed of many thin, parallel teal lines that curve and flow across the page, creating a sense of motion and depth.

Producer:
Arka Sp. z o.o.
arka-instalacje.pl