

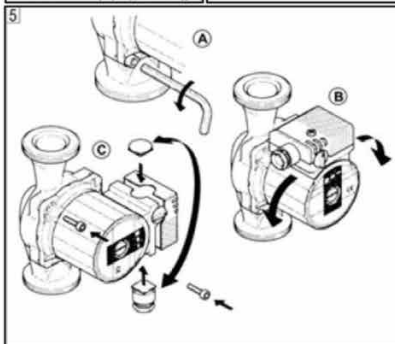

Circulating Pump

User Manual

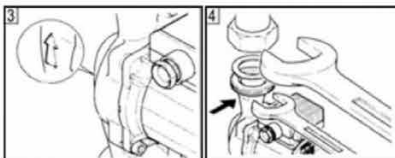

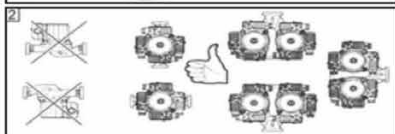
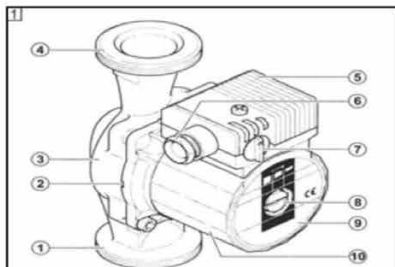
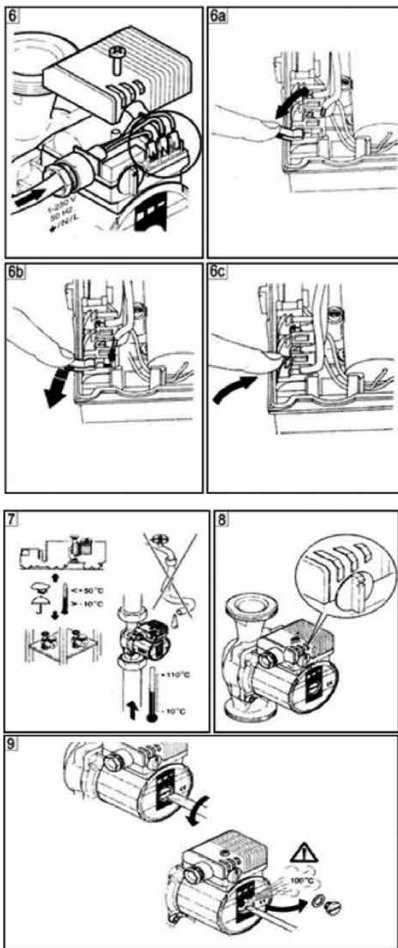

TABLE OF CONTENTS

1. General Information/Characteristics
2. Safety
3. Transport/Storage
4. Description of the pump and accessories
5. Connection/Installation
6. Operation
7. Service
8. Failures, Causes and Their Removal
9. Spare Parts
10. Warranty Card
11. Post-Warranty Service

1. General Information



The Circula circulation pump can only be used for drinking water in accordance with Commission Regulation (EC) No. 641/2009.

The pump manual applies to the following types of circulation pumps: PC15/60 130, PC25/60 130, PC 25/40 180, PC25/60 180, PC25/80 180, PC32/80 180.

Type designation

PC /

Type designation Circulation pump

for drinking water, without sealing

Nominal diameter of connections [mm] 15 (1"), 25 (6/4"), 32 (2")

Maximum height of lift [m]

Installation length [mm]

Hydraulic characteristics

PC 25/40 180

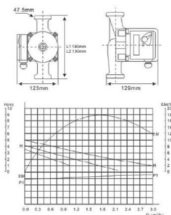

PC 25/60 130 a PC 25/60 180

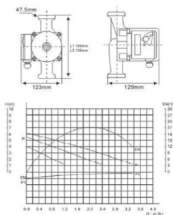

PC 25/80 180

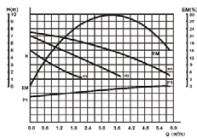
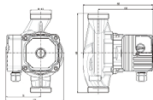

PC 32/60 180

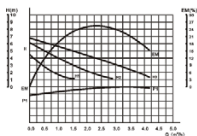
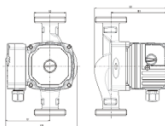

PC 15/60 130

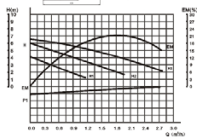
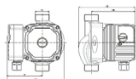

PC 32/80 180

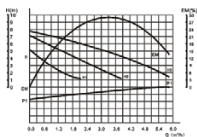
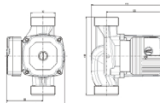

Description of the pump (fig. 1)

1. Suction stub
2. Condensate drain
3. Motor housing
4. Discharge branch
5. Control panel
6. Power supply gland
7. Speed switch
8. Air vent screw
9. Name plate
10. Motor casing

Data regarding connection and performance

Power supply voltage: 1~230V \pm 10%

Frequency: 50Hz

Max power consumption:

Rating plate Max motor speed: Rating plate

IP protection class: Rating plate

Speed levels: 3 channels*

Mounting length: 130/180 mm

Permissible working pressure, max.: 10 bar

Permissible liquid temperature min./max.: -10/+110°C

Permissible ambient temperature, max.: +40°C

Minimum inlet pressure* in the suction port at

+50°C: 0,05 bar

+95°C: 0,3 bar

+110°C: 1,0 bar

*Values are important for altitudes up to 300 m above sea level; for higher elevations, an addition of 0.01 bar per 100m increase in altitude is required. To avoid cavitation, sufficient inlet pressure must be ensured in the pump's suction line.

Translated liquids:

- drinking water according to local sanitary regulations

2. Safety

This manual contains basic recommendations that must be followed during the installation and operation of the device. This instruction must be read before starting the pump.

Familiarize yourself with the instructions before performing the installation and starting the pump.

Warning markings

The safety markings contained in this operating instruction, non-compliance with which may pose hazards to individuals, are marked with a general danger symbol:

General hazard symbol:



when warning about electric voltage by:



For safety recommendations, non-compliance with which may result in improper operation or damage to the device, the word has been added:

WARNING!

Staff Qualifications

The personnel performing the assembly must have qualifications appropriate for this type of work.

Dangers resulting from non-compliance with recommendations

Non-compliance with safety recommendations can pose risks to individuals and cause damage to the pump or installation. Non-compliance can lead to the loss of the ability to obtain compensation for damages resulting from the operation of the device. In particular, non-compliance can, for example, cause:

- improper operation of the pump or installation
- risks to individuals caused by electrical and mechanical interactions.

Recommendations for users

One must adhere to the applicable regulations regarding workplace safety. Hazards arising from the use of electricity must be eliminated. Local regulations and directives of the local power company must be followed.

Recommendations for assembly and inspection works

The user should ensure that all inspection and assembly work is carried out by qualified personnel with the appropriate qualifications. This personnel should be thoroughly familiar with the assembly and operation instructions. All work on the pump/device should be carried out while it is stopped.

Use of improper spare parts and unauthorized interference

Any changes made to the pump/device are only permissible after prior consultation with the manufacturer. Using original spare parts authorized by the manufacturer increases operational safety. When using other spare parts, the manufacturer is not responsible for the resulting consequences.

Unacceptable methods of work

Safe operation of the supplied pump/device is guaranteed only by adhering to the first point of the instructions. The limit values provided in the instructions must not be exceeded under any circumstances.

3. Transportation and storage

NOTE!

The pump contains electronic elements and should be protected from external moisture and mechanical damage (due to impacts/shocks) as shown in figure 7. The pump must not be exposed to temperatures outside the range of -10°C to $+50^{\circ}\text{C}$.

Recommendations for users

The applicable safety regulations must be observed. Dangers arising from the use of electricity must be excluded. Observe local regulations and the guidelines of the local energy company.

4. Description of the pump and accessories

The package includes:

- a complete pump
- a set of connection fittings *(pump CI-PC15/60-130 BS without half fittings)
- 2 flat gaskets
- operating instructions
- electric cable

Description of the pump

In non-seal type pumps, the rotor is submerged in the flowing medium. Additional rotor seals are not required. The pumped liquid cools and lubricates the rotor bearings. Additional overload protection for the motor is not necessary. Even the maximum overload current cannot damage the motor. The motor is resistant to current when locked.

Service hotline: 889 808 808

Type of regulation (fig. 8)

The pump regulation channel is selected using a 3-step switch. At speed 1, the rotational speed is 40...50% of the maximum achievable at speed 3, and speed consumption is reduced to 50%. At speed 3, the pump reaches its rated output. Speeds 2 and 3 are used to reduce the pump's output.

WARNING!

Only qualified personnel can perform the installation and commissioning!

5. 5. Installation/Assembly

- Installation should only take place after all welding and soldering work is completed and after the necessary flushing of the system. Contaminants can damage the pump.
- Install the pump in an easily accessible location for maintenance and inspection purposes.
- It is recommended to install shut-off valves before and after the pump. This way, during a potential pump replacement, there will be no need to drain and refill the system. The fittings should be installed in such a way that any liquid droplets from possible leaks do not fall onto the pump motor or the pump's electrical module.
- The pump should be installed in such a way that stresses from the installation do not transfer to the pump housing. The pump shaft should be in a horizontal position (fig. 2).
- The directional arrow on the pump housing indicates the flow direction (fig. 3, pos. 1).
- When tightening the pump's half-couplings, its housing should be secured with a flat wrench (fig. 4).
- During the installation of the pump, care should be taken to ensure that the electrical box is positioned either at the top or the side (fig. 5).

WARNING!

Do not damage the flat gasket. If necessary, use a new gasket: 086 x Ø76x2.0mm EP. In thermally insulated installations, only the pump casing can be insulated. The motor and condensate drain openings must remain unobstructed (Fig. 3, Position 2).

Electrical connection



The electrical connection should be made in accordance with applicable local regulations by an electrician with the qualifications required by the local power company.

To ensure protection against dripping water and to relieve the cable gland from stretching, a connection cable of appropriate length and sufficient outer diameter should be used (e.g. H 05 VV-F 3 G 1.5).

When operating the pump at temperatures above 90°C, an electrical connection cable with insulation of appropriate thermal resistance should be used.

- The electrical connection cable should be routed in such a way that it does not touch the installation or the motor housing under any circumstances.
- The type of current and voltage must correspond to the data on the pump's nameplate.
- Connect to the network according to fig. 6.

The electric connection cable must be passed through the cable gland from the right or left side. If necessary, the side of the installed cable gland can be changed. When making a side connection, the cable should be connected from the bottom (see fig. 5).



After connecting to the electrical network, close the electric module of the pump again to protect against moisture.

- Ground the pump according to regulations.

6. Start-Up

Filling and Venting

Air venting of the pump is necessary during the first start-up of the pump and during each start after draining the installation of drinking water.

The installation should be carefully filled with water. The venting of the pump's rotor space occurs automatically after a short period of operation. A brief dry run does not damage the pump. If venting of the rotor space is necessary, proceed as follows:

- Carefully unscrew the vent plug using a suitable screwdriver and completely remove it (Fig. 9).
- After 15...30 seconds, screw the vent plug back in.



Danger of burns when touching the pump!

In certain operating states of the pump and installation (the temperature of the fluid being pumped), the pump/motor can be very hot.



Danger of burns!

With high temperature of the fluid being pumped and high pressure in the system, opening the vent plug may result in the spillage or spraying of hot pumped fluid in liquid or vapor form under high pressure.

Starting the pump after a long downtime:

After a long downtime, the pump may become partially blocked due to water hardness or its specific chemical composition depending on the local drinking water supplier. In this case, you should (see fig. 9):

- turn on the pump
- unscrew the cap with a suitable screwdriver, move the motor shaft to the left and right
- turn the pump on again
- bleed the pump
- screw the cap back on.

Scope of regulation

The pump's performance can be adjusted according to local needs.

Switching the pump's rotational speed is done using a 3-position selector switch in the pump's electrical module.

7. Maintenance



Before starting maintenance work, disconnect the pump from the power supply and eliminate the possibility of unwanted reconnection.

8. Failures, causes and their removal If the pump is not working with the power supply on:

- check the fuses
- check the voltage and its value on the pump (pay attention to the nameplate data)
- the motor is blocked, for example, by deposits from the heating water.



At high water temperatures and high system pressure, close the shut-off valves upstream and downstream of the pump. However, wait until the pump has cooled down before doing so.

If the pump is operating loudly:

- for cavitation noises caused by insufficient pressure, increase the supply pressure,
- select the appropriate pump rotational speed.

9. Spare parts

When ordering spare parts, all information from the nameplate must be provided.

10. Warranty Card



Pump model	Seller's stamp	Date of sale – seller's signature

Company Arka Sp. z o.o. provides a 24-month warranty on the product, starting from the date of sale, provided that the Buyer follows the installation, usage, and maintenance instructions. The warranty covers only factory defects: materials and workmanship that occurred during the manufacturing process.

The warranty does not cover damages:

- mechanical defects,
- resulting from the assembly of the pump not complying with the assembly instructions or unauthorized interference,
- resulting from improper use or handling of the pump,
- resulting from the ingress of solid contaminants into the pump,
- resulting from freezing, atmospheric discharges, or faults in the electrical installation, particularly dampness of electrical connections,
- damage resulting from the pump operating in a dry run.

The basis for considering a warranty complaint by the company Arka is having proof of purchase and this warranty card.

Complaint submissions are accepted:

- at the point of sale where the product was purchased, to be delivered along with the defective goods.

The above documents should be sent electronically to: serwis@arka-instalacje.pl, the form can be downloaded from the website arka-instalacje.pl. The hotline 889-808-808 is available on weekdays from 8:00 AM to 4:00 PM. This warranty does not exclude, limit, or reduce the buyer's rights resulting from the non-conformity of the goods with the contract. The warranty is valid only in Poland.



METHOD OF DISPOSAL OF USED EQUIPMENT

This pump is marked in accordance with European Directive 2012/19/EU and the Polish Act of September 11, 2015, "On Waste Electrical and Electronic Equipment" (Journal of Laws of October 23, 2015, item 11688) with the symbol of a crossed-out waste container. Such marking informs that this equipment, after its period of use, cannot be disposed of together with other household waste. The user is obliged to return it to entities conducting collection of waste electrical and electronic equipment. Collectors, including local collection points, stores, and municipal units, create a suitable system for returning this equipment. Proper disposal of waste electrical and electronic equipment contributes to avoiding harmful consequences for human health and the natural environment that arise from the presence of hazardous components and improper storage and processing of such equipment.

Deklaracja zgodności WE

Deklarujemy z pełną odpowiedzialnością, że produkt:

Pompa cyrkulacyjna do wody pitnej marki CIRCULA zgodnie z rozporządzeniem Komisji Europejskiej (WE) nr 641/2009

Model:

- CI-PC 15/60-130
- CI-PC 25/40-180
- CI-PC 25/60-130
- CI-PC 25/60-180
- CI-PC 25/80-180
- CI-PC 32/60-180
- CI-PC 32/80-180

Producent:

ARKA Sp. z o.o. sp.k.
ul. Ogrodowa 5
76-004 Sianów

do którego odnosi się niniejsza deklaracja, spełnia zasadnicze wymagania:

Dyrektyw EC:

2006/95/EC Dyrektywa niskiego napięcia
2004/108/EC Dyrektywa kompatybilności elektromagnetycznej

Norm zharmonizowanych:

PN-EN 55014-1, PN-EN 55014-2, PN-EN 60335-1, PN-EN 60335-2-41,
PN-EN 61000-3-3, PN-EN 61000-4-2, PN-EN 61000-4-4, PN-EN 61000-4-5,
PN-EN 61000-4-6, PN-EN 61000-4-11

Deklaracja dotyczy tylko i wyłącznie produktów w stanie w jakim zostały wprowadzone do obrotu rynkowego. Deklaracja nie obejmuje części składowych dodanych przez użytkownika, dokonanych przez niego zmian, jak również użytkowania niezgodnego z instrukcją.

 ARKA Sp. z o.o. Sp. k.
76-004 Sianów, ul. Ogrodowa 5
REGON 330667270, NIP 659-22-21-025
arka-instalacja.pl

 ARKA Sp. z o.o. Sp. k.
Andrzej Pawtowski
Andrzej Pawtowski

Sianów, 1 grudnia 2016 r.

.....
(miejsce i data wystawienia)

.....
(podpis osoby upoważnionej)



Producer:
Arka Sp. z o.o.,
Ogrodowa 5, 76-004 Sianów
Poland
arka-instalacje.pl