



Electronic circulation pump

SELENIO

User manual

Table of Contents

1. INTRODUCTION	5
2. Types and dimensions	5
2.1 Models overview	5
2.2 Dimensions	6
3. Safety rules	7
4. Purpose and installation.....	8
4.1 Pumped liquids.....	8
4.2 Liquid temperature and ambient temperature	9
4.3 Installation	10
5. Characteristics and operation.....	11
5.1 Control panel - description.....	11
5.2 Pump settings	11
5.3 Automatic pump venting function.....	13
5.4 Pump start function	13
5.5 Hydraulic characteristics of pump	14
6. Technical data	16
7. Problems and solutions.....	16
8. Warranty card	18
9. Declaration of conformity	19

WARNINGS

Please read the following notes before starting the installation and use of the pump.

- ! Before starting the pump, make sure every time that the installation is filled with water and do not allow the pump to operate in dry conditions. Do not tighten or loosen the pump fittings and screws fixing the pump head under pressure.
- ! The pump should be installed by qualified personnel in accordance with this operating and installation manual and with good installation practice guidelines. The manufacturer is not responsible for damage caused by improper installation of the pump.
- ! When the pump operates with high temperatures of the heating medium, there is a risk of burns from contact with the pump body.
- ! In case of leaks from the installation that could threaten the pump's electronic systems, the power should be disconnected immediately.
- ! Pay attention during service of the electronic pump.



METHOD OF DISPOSAL OF USED EQUIPMENT

This pump is marked in accordance with European Directive 2012/09/EU and the Polish Act of September 11, 2015, "On Used Electrical and Electronic Equipment" (Journal of Laws of October 23, 2015, item 11688) with the symbol of a crossed-out waste container. This marking indicates that this equipment, after its period of use, must not be disposed of with other household waste. The user is obligated to hand it over to those conducting the collection of used electrical and electronic equipment. Proper handling of used electrical and electronic equipment helps avoid harmful consequences for human health and the natural environment, resulting from the presence of hazardous components and improper storage and processing of such equipment.

1. Introduction

In the electronic circulation pump, the motor stator is fully enclosed, and the rotating parts are immersed in pure water, which plays an important role in cooling and lubrication during operation. The pump's enclosing sleeve has a thin wall structure to completely shield the motor stator from water. The traditional design of mechanical seals has been eliminated, solving the leakage problem of conventional water pumps. The rotating elements are made of ceramic bearings and ceramic rotors, which are wear-resistant and lubricated with pure water, allowing them to cool the motor and reduce noise. The pump will not become overloaded when operating at full capacity. Essentially, the pump can be maintenance-free as long as it is used correctly.

2. Types and dimensions

2.1 Models overview

Overview of models

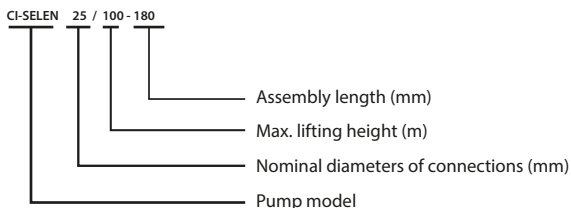

Model	Nominal diameter of the connection	Connection size	Max flow	Height of lift	Voltage	Frequency	Power	Current	EEI*
	mm		m ³ /h	m					
CI-SELEN 25/100-180	25	1 1/2"	7,5	0 - 10	230	50	140	0,07 - 0,95	≤0,23
CI-SELEN 32/100-180	32	2"	8	0 - 10			140	0,07 - 0,95	≤0,23
CI-SELEN 25/120-180	25	1 1/2"	8,5	0 - 12			180	0,12 - 1,18	≤0,23
CI-SELEN 32/120-180	32	2"	9	0 - 12			180	0,12 - 1,21	≤0,23

* The reference criteria for the most energy-efficient circulation pumps is $EEI \leq 0.20$.

2.2 Dimensions

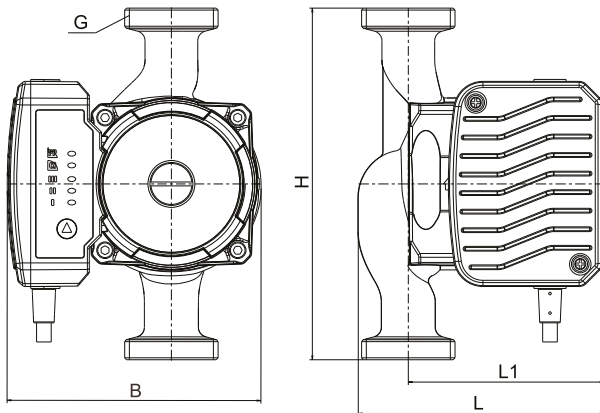

Model	Dimension (mm)					Net weight
	L	L1	H	B	G	
CI-SELEN 25/100-180	133	95	180	143	1 1/2"	3,1
CI-SELEN 32/100-180					2"	3,5
CI-SELEN 25/120-180					1 1/2"	3,1
CI-SELEN 32/120-180					2"	3,5

3. Safety rules



- Do not touch the pump housing while it is in operation.
- Do not operate the pump without water.

1. The power supply voltage of the electronic pump is single-phase 230 V, and the frequency is 50 Hz.
2. Before installation, ensure that the pipe system is securely connected and check that any debris, soldering residues, and waste have been removed from the pipes.
3. Make sure that the pump is located in a dry and ventilated environment to avoid short circuits caused by moisture or splashes in the housing and to ensure it is accessible for servicing and replacement.
4. It is recommended to install shut-off valves on the inlet and outlet nozzles to facilitate future servicing and maintenance of the pump.
5. Avoid touching the pump and/or other pipes to prevent burns.
6. To avoid accidents, disconnect the power supply before performing any servicing activities.
7. Regularly check the pump and replace it in case of any damage.
8. The power cord may only be replaced with appropriate wires or dedicated components.
9. In winter, when the ambient temperature is below 0°C and when the pump stops working to avoid pump damage due to frost, the water from the pipe must be completely drained.
10. The heating supply pipes cannot be frequently replenished with unsoftened water to avoid the accumulation of calcium inside the piping system and clogging the impeller.

4. Purpose and installation

4.1 Pumped liquids

Water in heating installations should comply with PN-C-04607:1993 and be free from solid particles, fibers, and contaminants.

The pump is intended for the following systems:

- non-aggressive, non-explosive liquids, free from solid particles and fibers,
- liquids intended for heating installations.



4.2 The temperature of the liquid and the temperature of the environment

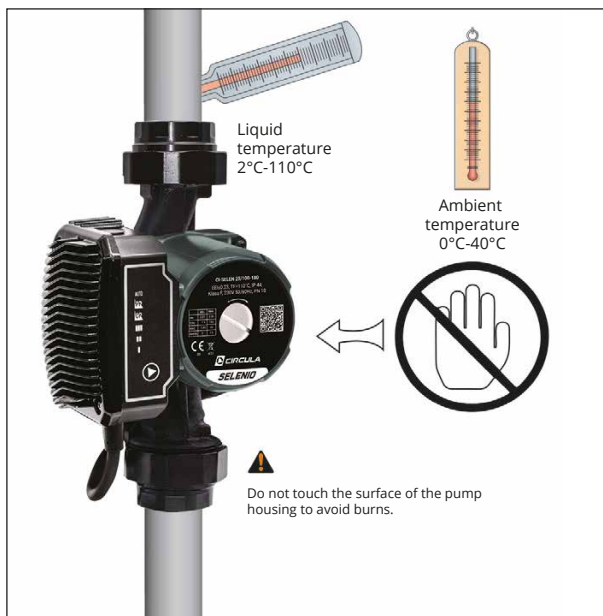

4.3 Installation

During assembly, the engine shaft must be positioned in a horizontal axis, the direction of the fluid flow in the pipe must be the same as the arrow marked on the pump housing.

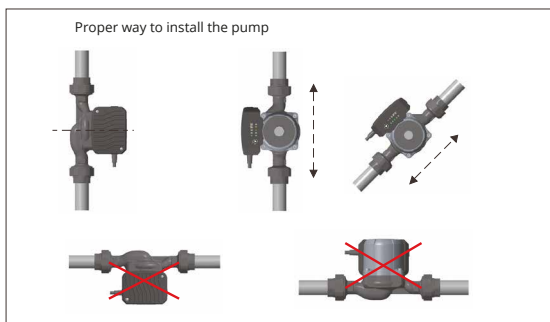
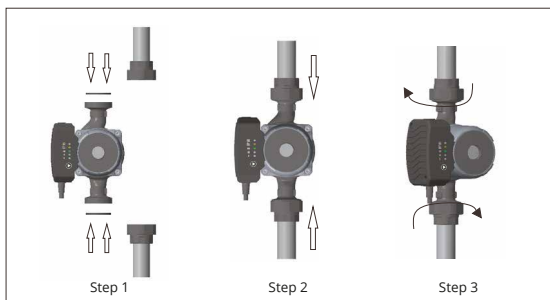

Changes in the position of the control box and the engine casing can only be made by the authorized service of Circula pumps.

5. Characteristics and operation

5.1 Control panel - description

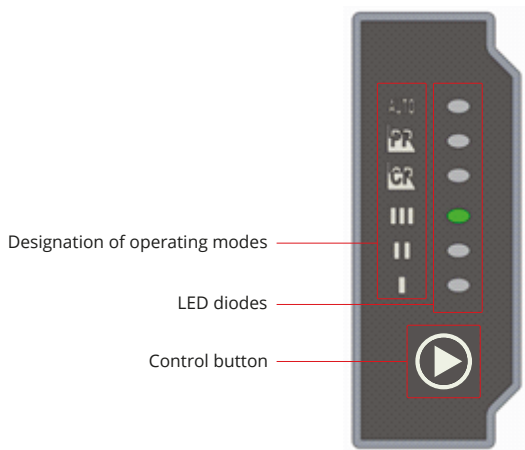

5.2 Pump Settings

After connecting the pump to the power supply, all LEDs will light up three times. Then, the current operating mode of the pump will be displayed.

The relationship between the setting of the electronic pump and the indications on the display:

Auto	PP I
Adaptive mode 	The curve of proportional pressure, speed I 
PP II	PP III
The curve of proportional pressure, speed II 	The curve of proportional pressure, speed III 
CP I	CP II
Constant pressure curve, speed I 	Constant pressure curve, speed III 
CP III	CS I
Constant pressure curve, speed III 	Curved line, speed I 
CS II	CS III
Curved line, speed II 	Curved line, speed III 

5.3 Automatic air vent function of the pump

The function is activated by pressing and holding the button  for about 5 seconds until 3 LEDs light up (see illustration below).

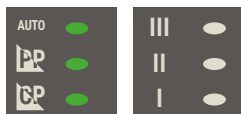

The pump switches to venting mode for 5 minutes: it will operate alternately at different speeds. After the automatic venting is completed, the pump returns to the previously set operating mode.

5.4 Pump start function

In the case of rotor blockage, for example after a long downtime of the pump, it is possible to activate the pump start function. The function is triggered by holding the button  for about 8 seconds until all 6 LEDs light up (see illustration below).

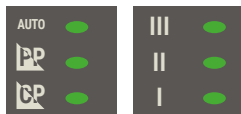

For 5 minutes, the pump enters the rotor startup mode, which means cyclic attempts to start at maximum speed. In the case of a successful rotor start, the pump returns to the previously set operating mode. However, in the event of a failed rotor start, an error code indicating protection against rotor locking will be displayed on the pump screen (see illustration below).

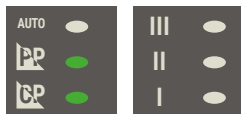

5.5 Hydraulic characteristics of pumps

CI-SELEN 25/100-180

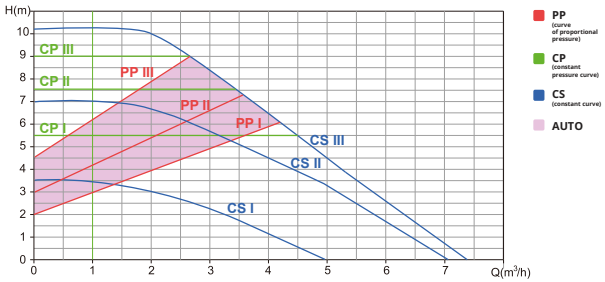

CI-SELEN 25/120-180

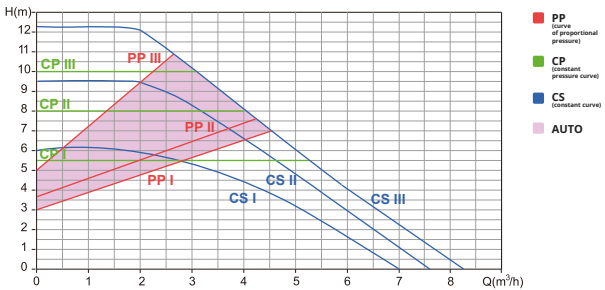

CI-SELEN 32/100-180

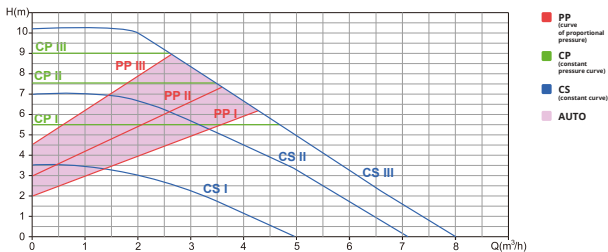

CI-SELEN 32/120-180

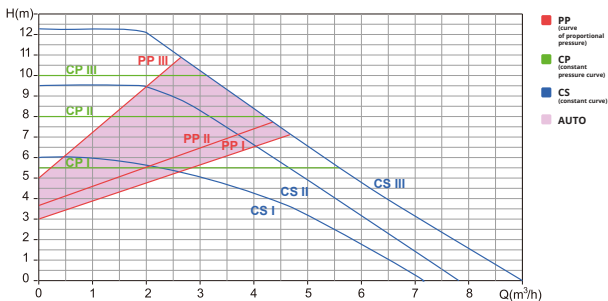





6. Technical data

Power supply voltage	230 V, 50 Hz			
Protection class	IP44			
Insulation class	F			
Relative humidity	Max. 95%			
Installation pressure	Max. 1.0 MPa, 10 bar			
Inlet pressure	Liquid temperature	≤ +75°C	Min. inlet pressure	0,05 bar , 0,005 MPa
		+90°C		0,28 bar , 0,028 MPa
		+110°C		1,08 bar , 0,108 MPa
Liquid temperature	2°C-110°C			

7. Problems and solutions

Problem	Likely Cause	Solution
The pump is not working	Incorrect connection of the power cord	Make sure the power cord is connected correctly
	Blown fuse	Replace the fuse
Noise in the system or pump housing	Contaminants inside the pump, blocked impeller	Disassemble the pump and remove any dirt
	The set flow is too high	Switch to lower speed
	Air in the system or pump housing	Remove air / bleed pump
The pump is working but is not generating any pressure.	The inlet valve is closed	Open the valve
	Air in the installation	Vent the system and pump

In the event of a malfunction, the pump's electronics will respond to certain faults and secure the pump. The table below shows the safety codes on the display panel:

Displayed message	Error cause	Problem solution
	Rotor blocked	Clean the rotor and the installation from contaminants
	Phase disappearance	Check the power supply voltage
	The power supply voltage is too low or too high.	Check the power supply voltage. In case of further problems, contact an authorized service.
	Short circuit in the pump	Contact an authorized service center

8. Warranty card

Pump model	Seller's seal	Sale date / Seller's signature

ARKA Company provides a 24-month warranty on the product, starting from the date of sale, provided that the Buyer follows the installation, use, and maintenance instructions. The warranty covers only manufacturing defects in materials and workmanship that occur during the production process.

The warranty does not cover:

- mechanical damage,
- damage resulting from the installation of the pump contrary to the installation instructions or unauthorized interference,
- damage resulting from improper use or operation of the pump,
- damage resulting from the ingress of solid contaminants into the pump,
- damage resulting from freezing, lightning strikes, or faults in the electrical installation, particularly moisture in electrical connections,
- damage resulting from operating the pump on a dry run.

The basis for considering a complaint under warranty by ARKA is possession of the proof of purchase and this warranty card.

Complaints can be submitted:

- through the point of sale where the product was purchased - in this case, the above documents must be provided along with the defective goods,
- electronically: via the form on the website, fax /94/ 346-27-68,
- hotline 889-808-808 (on working days from 8:00 AM to 4:00 PM).

This warranty does not exclude, limit, or diminish the buyer's rights arising from the non-conformity of the goods with the contract.

9. Declaration of conformity



Declaration of Conformity UE

No. 2/circula/2021

1. Model produktu:

CIRCULA SELENIO - POMPA ELEKTRONICZNA C.O.

Kod produktu (indeks): CI-SELEN 25/100-180; CI-SELEN 32/100-180; CI-SELEN 25/120-180; CI-SELEN 32/120-180

2. Nazwa i adres producenta lub jego upoważnionego przedstawiciela:

ARKA Sp. z o.o. sp.k.
ul. Ogrodowa 5
76-004 Ślanów

3. Niniejsza deklaracja zgodności wydana zostaje na wyłączną odpowiedzialność producenta.

4. Zgodność przedmiotu deklaracji potwierdzona certyfikatem:

Certyfikat nr: ISETC.001320210205 wydany przez: ISET S.r.l. Unipersonale
Certyfikat nr: D6 101057 0060, D6 101057 0061, D6 101057 0062, D6 101057 0063
wydane przez: TÜV SÜD Product Service GmbH

5. Wymieniony powyżej przedmiot deklaracji niniejszej deklaracji zgodności UE jest zgodny z odpowiednimi wymaganiami unijnego prawodawstwa harmonizacyjnego:

Dyrektywa 2014/35/UE (LVD)
Dyrektywa 2014/30/UE (EMC)
Dyrektywa 2006/42/WE (MD)
Dyrektywa 2009/125/WE (Ekoprojekt)

6. Odniesienia do odpowiednich norm zharmonizowanych, które zastosowano, lub do innych specyfikacji technicznych, w stosunku do których deklarowana jest zgodność:

EN 16297-1:2012
EN 16297-2:2012
EN 16297-3:2012
EN ISO 12100:2010
EN 809:1998+A1:2009+AC:2010
EN 60204-1:2018
EN 61000-3-3:2013+A1:2019
EN 60335-1:2012+A11:2014+A13:2017+A1:2019+A14:2019+A2:2019
EN 60335-2-51:2003+A2:2012
EN 6034-1:2010+AC:2010
EN 62233-2008+AC:2008
EN 55014-1:2017+A11:2020
EN 55014-2:2015
EN IEC 61000-3-2:2019

Ślanów, 18 listopada 2021 r.

(miejsce i data wystawienia)

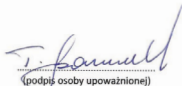
(podpis osoby upoważnionej)

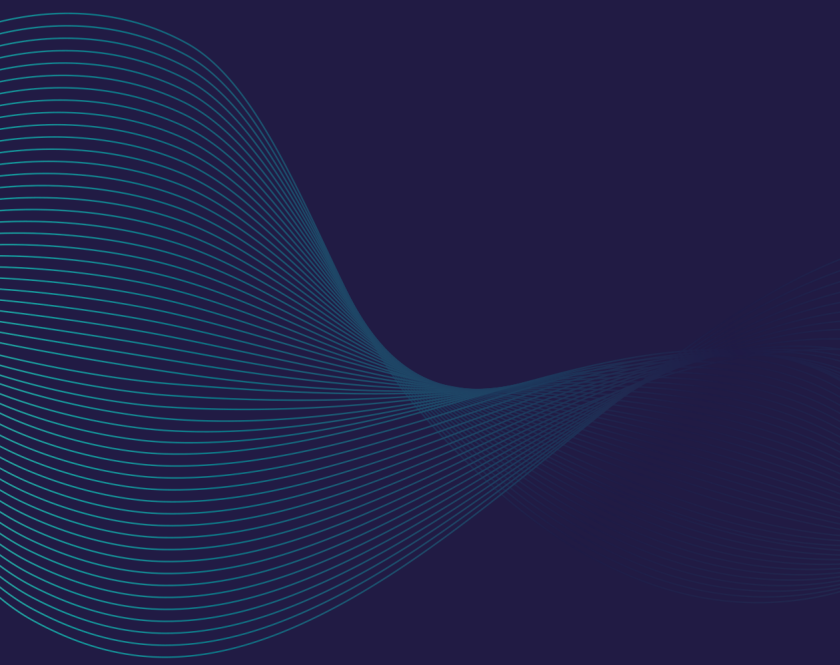

Producer:

Arka Sp. z o.o.,
Ogrodowa 5, 76-004 Sianów
Poland
arka-instalacje.pl