



Electronic circulation pump

# TORIO

User manual

# Operating and assembly instructions

1. Warning signs	2
2. Safety rules	3
3. General information	3
4. Transport and storage	3
5. Pump characteristics	4
6. Installation	5
7. Maintenance and service	6
8. Problems and solutions	7
9. Warranty service	7
10. Post-warranty service	8

# 1. WARNING SIGNS

You should familiarize yourself with the following notes before starting the installation and use of the pump.



Before starting the pump, it is necessary to ensure every time that the installation is filled with water and to avoid operating the pump in a dry run. Do not tighten or loosen the pump fittings and the screws securing the pump head under pressure.



The pump should be installed by qualified personnel in accordance with this operating and installation manual and with good installation practices. The manufacturer is not liable for damage caused by improper installation of the pump.



During the operation of the pump with high heating medium temperatures, there is a risk of burns upon contact with the pump housing.



In the event of leaks from installations that may threaten the electronic systems of the pump, the power supply must be immediately disconnected.



Pay attention when servicing the electronic pump.

- a. The electronic circulation pump is designed to force circulation in hot water supply systems. The maximum temperature of the heating medium is 95°C. Unauthorized interference with the pump's mechanical system may lead to injuries.
- b. The maximum temperature for the supplied liquid should not exceed the maximum temperature specified on the nameplate.
- c. This product must not be used in a high humidity environment or underwater!
- d. The pump should be protected with appropriate surge and overload fuses, in accordance with local electricity supplier regulations.
- e. The pump should be installed in such a position that the motor's axis of rotation is in a horizontal position. Otherwise, the motor will be damaged!

## 2. SAFETY RULES

Safety instructions:

- the product may only be installed and serviced by qualified personnel in accordance with the requirements of the local utility company.
- the manufacturer is not responsible for damage to the product caused by failure to comply with this instruction.
- in case of a pump malfunction, do not attempt to repair it yourself. Please contact our service within 48 hours or your local distributor. We are not liable for damages resulting from self-attempts to repair the pump.
- before sending the pump back to the manufacturer for a warranty claim, it must be cleaned and dried.



Before installing the pump, one should familiarize themselves with the parameters and values listed on the pump's nameplate, such as: liquid temperature, pressure, voltage, and other values. Supplying the pump with incorrect voltage may cause damage to it.

## 3. GENERAL INFORMATION

### Introduction

This instruction contains important information regarding the transport, installation, and operation of the electronic pump. It is necessary to follow the operating and installation instructions and to avoid any hazards associated with unauthorized interference in the pump's operation. Such actions may result in the loss of warranty and the right to compensation. Please read the instructions carefully before installing and using the pump.

### Application

The pump is designed for use in domestic hot water systems.

## 4. TRANSPORT AND STORAGE

Appropriate storage and transport conditions for the pumps must be ensured. The manufacturer is not responsible for damage and pump failures related to improper transport and storage.

## 5. PUMP CHARACTERISTICS

The pump instruction applies to electronic pumps of the type CI-TORIO 15/12

### Technical parameters:

- maximum water temperature in the installation: 95°C
- maximum working pressure: 10 bar
- insulation class: F
- energy class: A
- operating voltage: 220V-230 V, 50 Hz
- degree of protection: IP44
- pumped liquid: clean water, non-aggressive, non-explosive, free of mineral oils.

### Technical specifications

Model	Power (W)	Current (A)	Nominal flow (m <sup>3</sup> /h)	Maximum flow (m <sup>3</sup> /h)	Max. lift height (m)	Installation length (mm)	Connection diameter of the body (cal)
CI-TORIO 15/12	3 - 9	0,11	0,5	0,6	1,2	72	1/2

The pumps are equipped with a power cable and do not contain half-unions.

## 6. DIMENSIONS

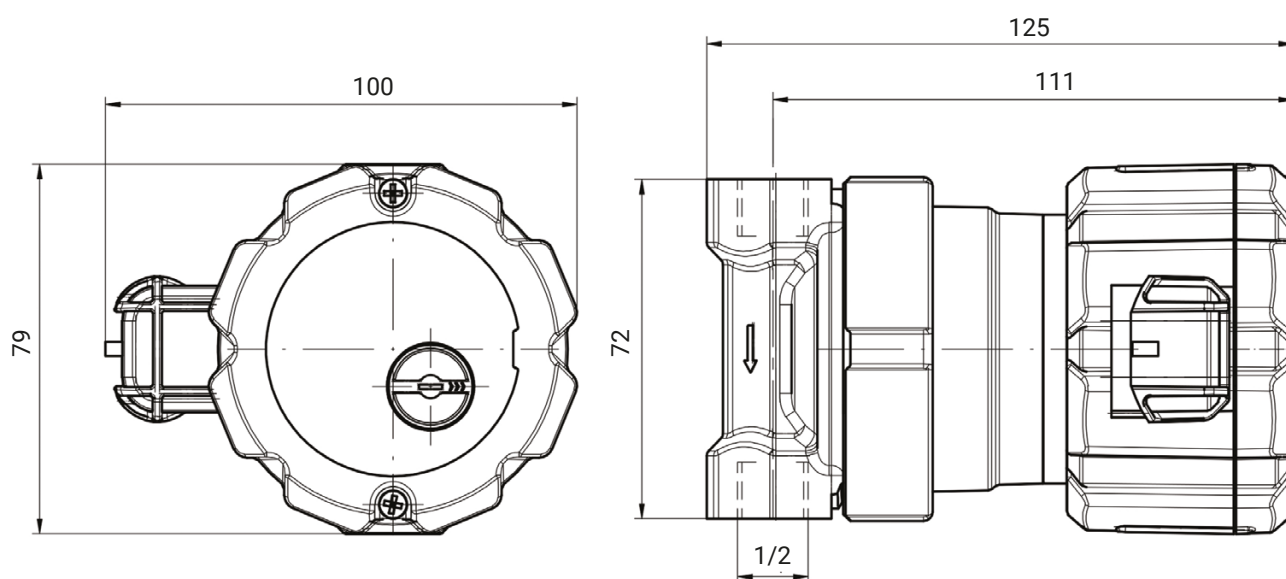

## Characteristics of pump operation

On the control panel, there is a knob that can be set to the automatic mode 'eco' or one of 6 speeds.

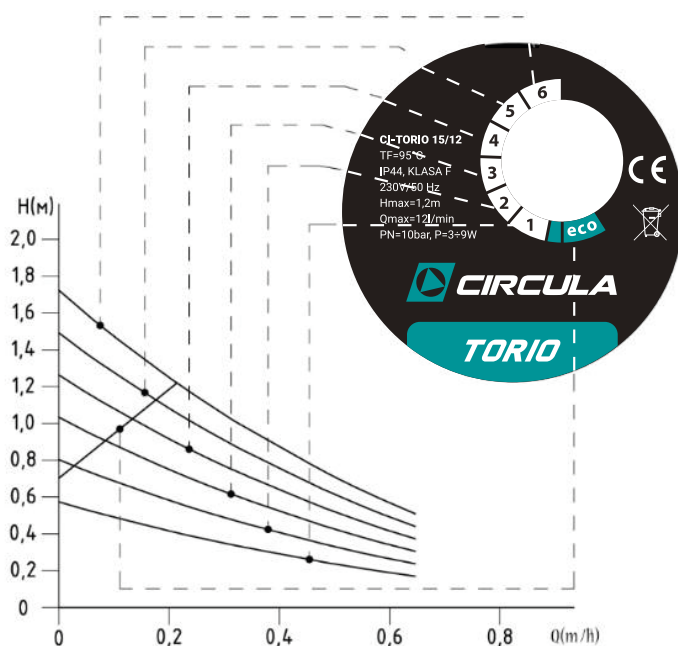

## 6. INSTALLATION

Preparation for installation

- The pump should be protected by appropriate overload protection devices.

Instructions for carrying out the installation



- The pump must be installed in such a way that the rotor axis is level. Otherwise, the motor will be damaged!
- The position of the pump's electrical connection can be changed according to needs.

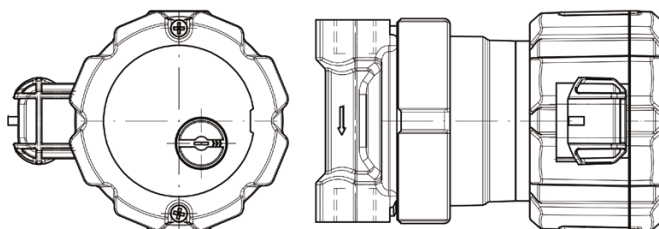

- It is recommended to install the pump on the return pipeline, i.e., before the domestic hot water storage tank.
- A check valve should be installed after the pump, on the discharge side, to prevent reverse water flow through the pump.

## Pump installation

- Before installation, check if the product is complete and undamaged.
- Check if the pipe connection diameters match the pump connection diameters.
- During installation, pay attention to the direction of liquid flow in the pump (flow according to the arrow embossed on the pump casing).

**NOTE: Do not turn on the pump without water in the installation.**

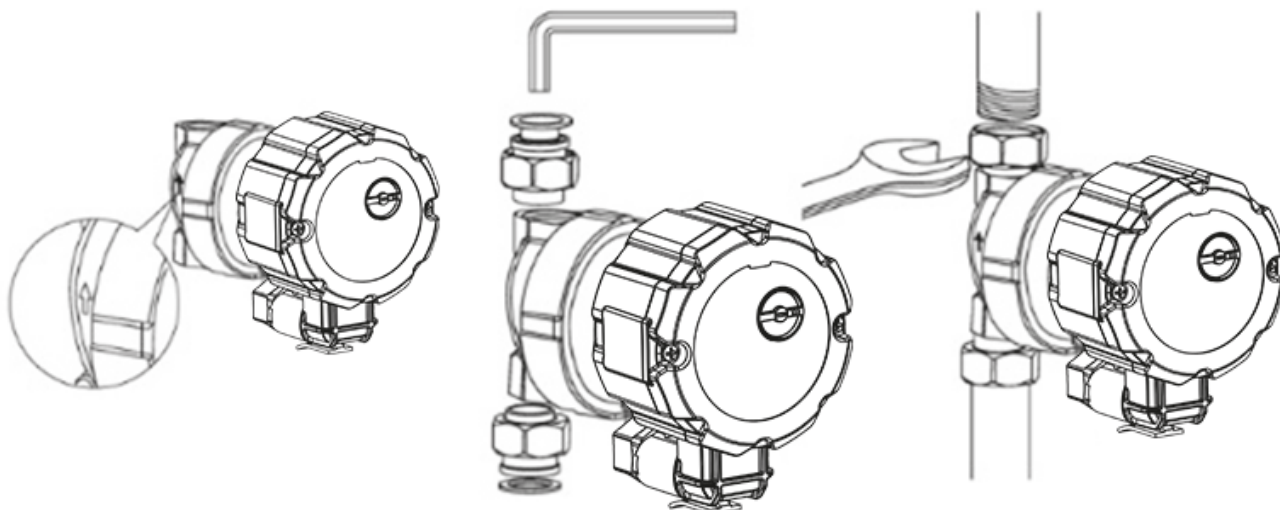

## 7. MAINTENANCE AND SERVICE

- In seasonal facilities where the installation temperature may drop below 0°C, appropriate measures should be taken to prevent the pump from freezing.
- The pump should be protected from contaminants with an appropriate filter.
- The pump should have the appropriate intake pressure secured on the suction side: 0.2m.



**Before dismantling the pump, it must be disconnected from the electrical power.**

## 8. PROBLEMS AND SOLUTIONS

### Problem

Difficulties in starting the pump

#### Cause

1. Too low voltage
2. Damaged wires, poor contact
3. Blocked impeller
4. Damaged motor

#### Solution

1. Ensure proper voltage
2. Check the quality of wires and connections
3. Clean the impeller
4. Service within 48 hours

### Problem

Insufficient flow

#### Cause

1. Improper installation
2. Valve is not fully open
3. Obstruction or contamination in the system
4. Obstruction or contamination in the system

#### Solution

1. Contact the contractor
2. Fully open the valves
3. Clean the filters and the system
4. Contact the contractor

### Problem

Sudden stop of the pump

#### Cause

1. Blown external fuse
2. Blocked rotor
3. Damaged motor
4. Lack of voltage

#### Solution

1. Replace the fuse
2. Clean the rotor
3. Service in 48 hours
4. Check the power source

## 9. WARRANTY CARD

Pump model	Seller's seal	Date of sale / seller's signature

ARKA company provides a 24-month warranty on the product, counting from the date of sale, provided that the Buyer follows the assembly, usage, and maintenance instructions. The warranty covers only manufacturing defects: in materials and workmanship occurring during the production process.

The warranty does not cover:

- mechanical damages,
- damages resulting from the installation of the pump not in accordance with the installation instructions or unauthorized interference,
- damages resulting from improper use or servicing of the pump,
- damages resulting from the ingress of solid contaminants into the pump,
- damages resulting from freezing, atmospheric discharges, or faults in the electrical installation, particularly moisture at electrical connections,
- damages resulting from the pump operating in a dry run.

The basis for considering complaints under the warranty by ARKA Company is the possession of a proof of purchase and this warranty card.

Complaint submissions are accepted:

- through the point of sale where the product was purchased - in this case, the above documents must be submitted along with the defective product,
- electronically: via the form on the website, fax /94/ 346-27-68, helpline 889-808-808 (on weekdays from 8:00 AM to 4:00 PM).

This warranty does not exclude, limit, or reduce the buyer's rights arising from non-compliance of the goods with the contract. The warranty is valid only within the territory of Poland.



#### METHOD OF DISPOSAL OF USED EQUIPMENT

- a. This pump is marked according to European Directive 2012/19/EU and the Polish Act of September 11, 2015
- b. "On waste electrical and electronic equipment" (Journal of Laws of October 23, 2015, item 11688) with the symbol of a crossed-out. Waste container. This marking indicates that after its use, this equipment must not be placed together with other household waste. The user is obliged to return it to the entities collecting used electrical and electronic equipment. Those collecting, g. including local collection points, shops, and municipal units, create an appropriate system enabling the return of this equipment. Proper handling of used electrical and electronic equipment helps to avoid harmful consequences for human health and the natural environment, resulting from the presence of hazardous components. and improper storage and processing of such equipment



**Producer:**  
Arka Sp. z o.o.,  
Ogrodowa 5, 76-004 Sianów  
Poland  
[arka-instalacje.pl](http://arka-instalacje.pl)