



Electronic pump

MERCURIO PRO

Operating manual

Contents

1.	Warning symbols	3
2.	Safety rules	4
3.	General information	4
4.	Transport and storage	4
5.	Pump characteristics	5
6.	Installation	14
7.	Maintenance and servicing	15
8.	Problems and solutions	16
9.	Warranty card	17
10.	Post-warranty service	18

1. WARNING SYMBOLS

Please read the following notes before starting the installation and use of the pump.



Before starting the pump, always ensure that the system is filled with water and do not allow the pump to run dry. Do not tighten or loosen the pump unions or the bolts securing the pump head while the system is under pressure.



The pump is not intended for installation in potentially explosive atmospheres.



The pump should be installed by qualified personnel in accordance with this operating and installation manual and in line with good installation practice. The manufacturer shall not be liable for damage caused by improper installation of the pump.



During operation with high temperatures of the heating medium, there is a risk of burns upon contact with the pump body.



In the event of leaks from the system that may endanger the pump's electronic components, the power supply must be disconnected immediately.



Exercise caution when servicing the electronic pump.

- a) The electronic circulation pump is intended for increasing pressure in central heating systems. The maximum temperature of the heating medium is 95°C.
- b) This product must not be used in high-humidity environments or under water.
- c) The pump must be protected by appropriate overvoltage and overload protection devices in accordance with applicable standards and national regulations.
- d) The pump must be installed in such a position that the motor shaft is horizontal. Otherwise, the motor will be damaged.

2. SAFETY RULES

Safety instructions

- The product may only be installed and serviced by qualified personnel.
- The manufacturer shall not be liable for damage to the product resulting from failure to follow this manual.
- In the event of a pump malfunction, do not attempt to carry out repairs yourself. Please contact our 48-hour service centre or a local distributor without delay. We accept no liability for damage resulting from unauthorised attempts to repair the pump.
- Before returning the pump to the manufacturer for a warranty claim, it must be cleaned and dried.



Before installing the pump, familiarise yourself with the parameters and values indicated on the pump's nameplate, such as fluid temperature, pressure, voltage, and other specifications. Supplying the pump with incorrect voltage may result in damage.

3. GENERAL INFORMATION

• Introduction

This manual contains important information regarding the transport, installation and operation of the electronic pump. Follow the operating and installation manual and avoid hazards associated with unauthorised interference with the pump's operation. Failure to comply will result in the loss of warranty and any right to compensation. Please read this manual carefully before installing and operating the pump.

• Application

The pump has a wide range of applications in residential and industrial settings, central heating systems, air conditioning systems, solar installations, and heat pumps.

4. TRANSPORT AND STORAGE

Ensure appropriate conditions for the storage and transport of the pumps. The manufacturer shall not be liable for damage or failure of the pump resulting from improper transport or storage.

5. PUMP CHARACTERISTICS

This manual applies to electronic pumps of the following type:

CI-MER-PRO 25/80-180
CI-MER-PRO 25/80-130
CI-MER-PRO 32/80-180

Designation key

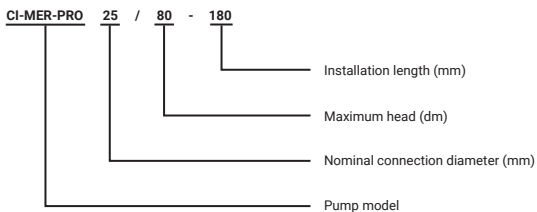

Technical specifications

- Maximum temperature of heating medium: **95°C**
- Maximum operating pressure: **10 bar**
- Insulation class: **F**
- Supply voltage: **220–230 V, 50 Hz**
- Degree of protection: **IP44**

Mercurio Pro								
Model	Power	Maximum flow rate	Maximum head	Voltage	Frequency	Maximum current	EEI	Pump body connection diameter
	W	m ³ /h	m	V	Hz	A		in
CI-MER-PRO 25/80-180	5–52	4.2	8	220–240	50	0.47	<0.2	1 1/2"
CI-MER-PRO 25/80-130	5–52	3.8	8			1 1/2"		
CI-MER-PRO 32/80-180	5–52	4.2	8			2"		

Dimensions

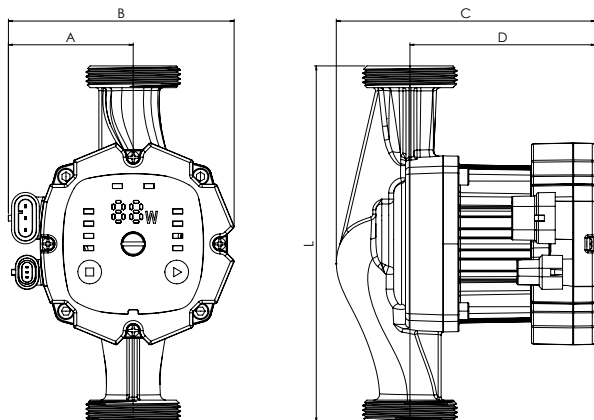

Model	Dimensions (mm)				
	A	B	C	D	L
CI-MER-PRO 25/80-180	63.1	114.1	130.9	93.6	180
CI-MER-PRO 25/80-130					130
CI-MER-PRO 32/80-180					180

Equipment

The pump is supplied complete with a power cable, PWM cable, and steel union fittings with rubber seals.



Pump performance curves for maximum heads

CI-MER-PRO 25/80-180

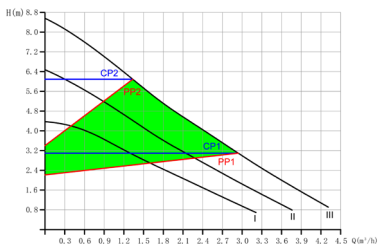

CI-MER-PRO 25/80-130

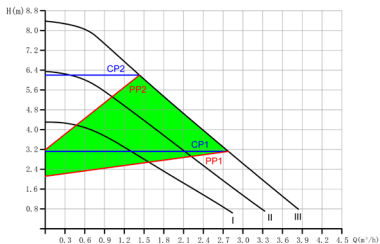



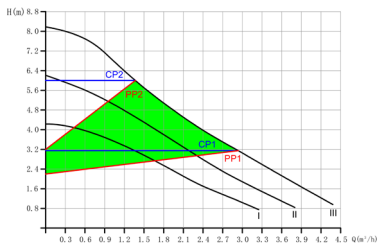

CI-MER-PRO 32/80-180



Head selection mode

The Mercurio Pro pump is equipped with a function allowing the user to adjust the head, enabling efficient operation of the system in which the pump is used.

Head selection instructions

1. With the power switched off, press and hold both buttons:  and . Then switch on the power supply. Keep the buttons pressed until numbers appear on the display.
2. To select the appropriate head value, press  or  (selecting the appropriate numerical code).

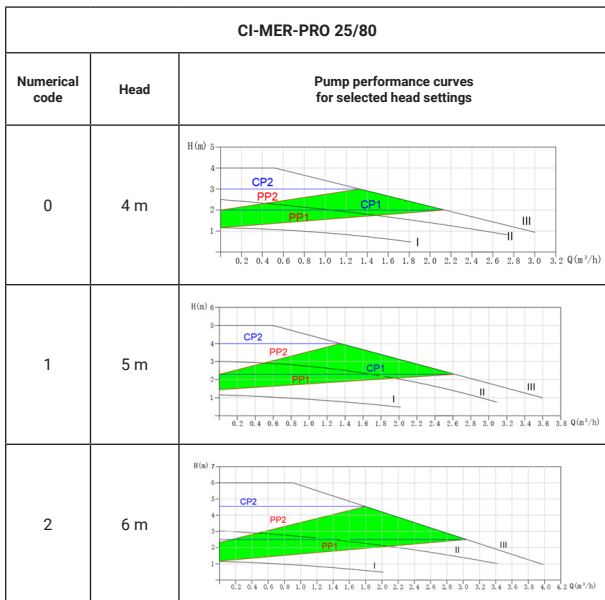

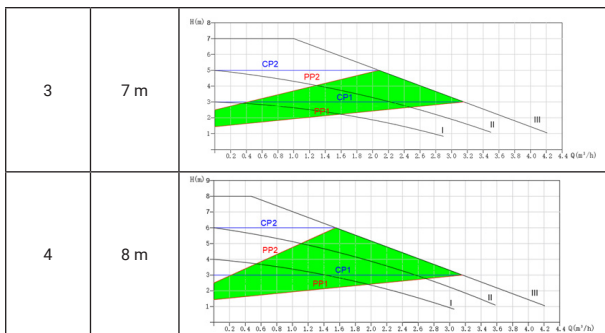

CI-MER-PRO 32/80

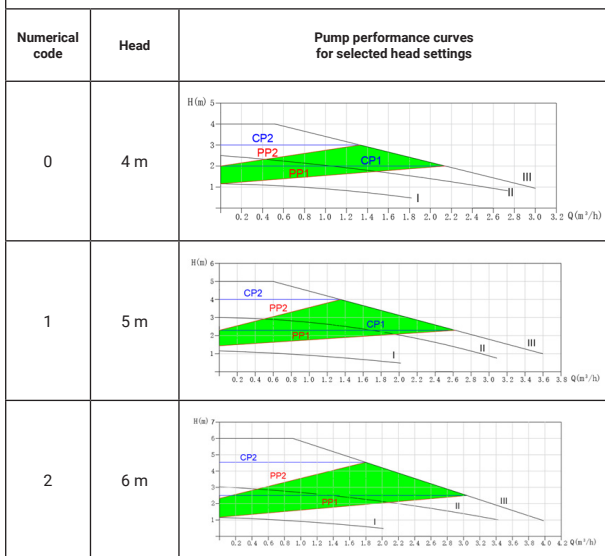

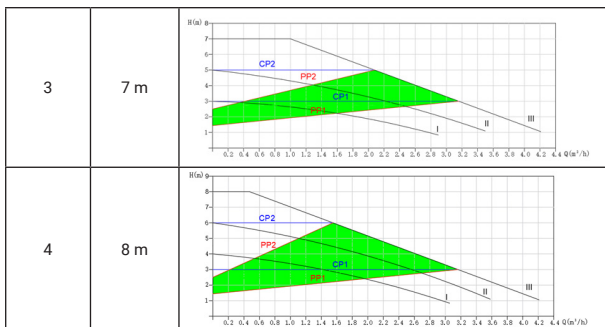

The **MERCURIO PRO** pump, thanks to an inspection sleeve located on the shaft axis, is equipped with a manual venting function and an emergency impeller start function (Protection right No. 232337).

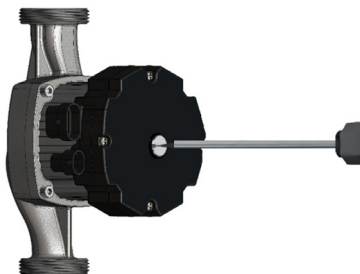

Control panel



No.	Mode	Description
1	Indicator of current power consumption / head setting / fault code symbol	Displays actual operating power during pump operation / numerical code corresponding to the selected head / each fault code is assigned a specific malfunction or irregularity
2	CP ₁ operating mode indicator	The pump operates at maximum constant pressure
3	CP ₂ operating mode indicator	The pump operates at minimum constant pressure
4	PP ₁ operating mode indicator	The pump operates with maximum proportional pressure setting
5	PP ₂ operating mode indicator	The pump operates with minimum proportional pressure setting
6	Speed mode III indicator	The pump operates at constant speed III
7	Speed mode II indicator	The pump operates at constant speed II
8	Speed mode I indicator	The pump operates at constant speed I
9	AUTO mode indicator	The pump automatically adjusts its power according to water flow
10	iPWM mode switch button	Selection of operating modes: iPWM GT, iPWM ST (short press)
11	Operating mode selection button	Selection of operating modes: I, II, III, AUTO, CP1, CP2, PP1, PP2 (short press)
12	iPWM ST mode indicator (solar)	The pump operates in iPWM ST mode
13	iPWM GT mode indicator (heating)	The pump operates in iPWM GT mode
14	Inspection sleeve plug	Enables additional pump venting and emergency impeller start

AUTO VENT mode

The AUTO VENT mode is activated by pressing and holding  for approximately 3–4 seconds. This mode operates for 10 minutes.

IPWM mode

The PWM signal is a series of pulses with a constant frequency but variable pulse width. The longer the pulse (higher duty cycle), the more energy is supplied to the pump and the higher the rotational speed. When the signal has shorter pulses, the pump operates at a lower speed. The PWM signal enables smooth speed regulation of the pump, allowing its operation to be adjusted to the specific requirements of the installation. The pump operates only at the power required at a given moment, which reduces energy consumption.

iPWM GT (heating)

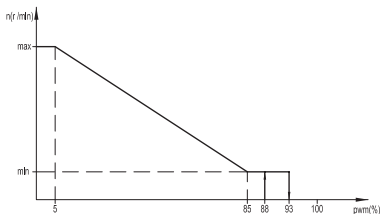

PWM input signal (%)	Pump operation
$0 < PWM \leq 5$	Maximum speed
$5 < PWM \leq 85$	Linear speed variation from max to min
$85 < PWM \leq 88$	Minimum speed
$88 < PWM \leq 93$	Hysteresis range: switch on/off
$93 < PWM \leq 100$	Standby mode: pump off

iPWM ST (solar)

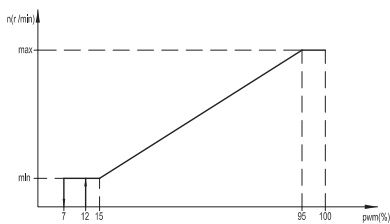

PWM input signal (%)	Pump operation
$0 < PWM \leq 7$	Standby mode: pump off
$7 < PWM \leq 12$	Hysteresis range: switch on/off
$12 < PWM \leq 15$	Minimum speed
$15 < PWM \leq 95$	Linear speed variation from min to max
$95 < PWM \leq 100$	Maximum speed

6. INSTALLATION

Preparation for installation



Warning!

- Do not touch the pump body during operation.
- Do not start the pump without water.
- The pump must be connected via a fuse to an external main switch. The pump must be earthed. The use of a residual current device is recommended.

Installation guidelines

The pump must be installed in such a way that the shaft axis is horizontal. Otherwise, the motor will be damaged.

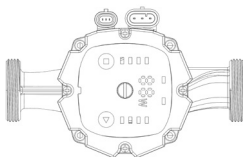
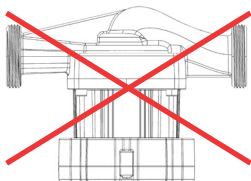
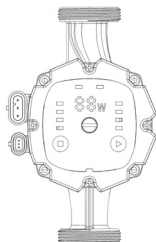
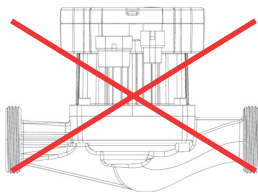

Pump installation

- Before installation, check that the product is complete and has not been damaged.
- Ensure that the connection diameters of the pipework match the pump connection diameters.
- During installation, pay attention to the direction of fluid flow through the pump.

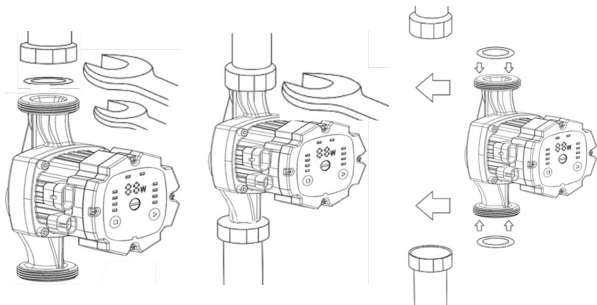

7. MAINTENANCE AND SERVICING

- In seasonal installations where the system temperature may drop below 0°C, appropriate measures must be taken to prevent the pump from freezing.
- The pump should be protected against contamination by an appropriate filter.
- The pump should operate with a minimum inlet pressure of 0.049 bar of heating medium.

8. PROBLEMS AND SOLUTIONS

Problem	Probable cause	Solution
Pump does not work	Incorrect power cable connection	Ensure that the power cable is connected correctly
	Fuse blown or switched off	Switch on or replace the fuse
	Activation of the overcurrent circuit breaker	Restore circuit continuity
	Motor failure	Service (48 h)
Noise in the installation or pump casing	Flow rate is too high	Select an appropriate operating mode
	Air in the system or pump casing	Remove air / Vent the pump
Insufficient flow	Inlet valve is closed	Open the valve
	Installation is air-locked	Vent the installation and the pump
	Blockage or contamination in the system	Clean the filters and the installation

The fault code is indicated by a specific symbol on the display panel	Fault code table	
	Fault code	Description
	E1	Impeller blocked
	E2	Phase failure or voltage too low
	E4	Electrical short circuit
	E5	Voltage too high

9. WARRANTY CARD

Pump model	Seller's stamp	Date of sale / Seller's signature

ARKA grants a 24-month warranty for the product from the date of sale, provided that the purchaser complies with the installation, operation, and maintenance manual. The warranty covers only manufacturing defects in materials and workmanship arising during the production process.

The warranty does not cover:

- mechanical damage;
- damage resulting from installation not in accordance with the installation manual or unauthorised interference;
- damage caused by improper use or handling of the pump;
- damage caused by the ingress of solid contaminants into the pump interior;
- damage caused by freezing, atmospheric discharges or defects in the electrical installation, in particular moisture in electrical connections;
- damage caused by dry running of the pump.

The basis for considering a warranty claim by ARKA is proof of purchase and this warranty card.

Claims are accepted:

- via the point of sale where the product was purchased – in this case, the above documents must be submitted together with the defective product;
- electronically – via the online form, fax /94/ 346 27 68;
- via hotline 889 808 808 (on working days, 8:00–16:00).

This warranty does not exclude, limit, or diminish the buyer's rights arising from non-conformity of the goods with the contract.

The warranty is valid only within the territory of the Republic of Poland.

10. POST-WARRANTY SERVICE

In the event of operational problems with the pump after the warranty period, please contact the 48-hour service*.



EU Declaration of Conformity

No. 3/circula/2025

1. Product model:

CI-MERCURIO – ELECTRONIC PUMP MERCURIO PRO FOR CENTRAL HEATING

Product code (index): CI-MER-PRO 25/80-180; CI-MER-PRO 25/80-130;
CI-MER-PRO 32/80-180; CI-MER-PRO 32/80-130

2. Name and address of the manufacturer or its authorised representative:

ARKA Sp. z o.o.
ul. Ogrodowa 5
76-004 Sianów

3. This declaration of conformity is issued under the sole responsibility of the manufacturer.

4. Conformity of the object of the declaration is confirmed by the following certificate:

Certificate No.: TD18712401

5. The object of the declaration described above is in conformity with the relevant Union harmonisation legislation:

Directive 2014/35/EU (LVD)
Directive 2014/30/EU (EMC)
Directive 2006/42/EC (MD)
Directive 2009/125/EC (Ecodesign)

6. References to the relevant harmonised standards applied or to other technical specifications in relation to which conformity is declared:

EN IEC 55014-1:2021; EN IEC 61000-3-2:2019+A1:2021
EN 61000-3-3:2013+A1:2019+A2:2021/AC:2022-01; EN IEC 55014-2:2021
EN 60335-1:2012+A11:2014+A13:2017+A1:2019+A14:2019+A2:2019
EN 62233:2008; EN 60335-2-41:2003+A1:2004+A2:2010
EN ISO 12100:2010; EN 809:1998+A1:2009+AC:2010

Sianów, 20 August 2025

.....
(place and date of issue)

Arka Sp. z o.o.
Tomasz Bamburak
Dyrektor ds. Wzrostu i Rozwoju B+R

(signature of authorised person)

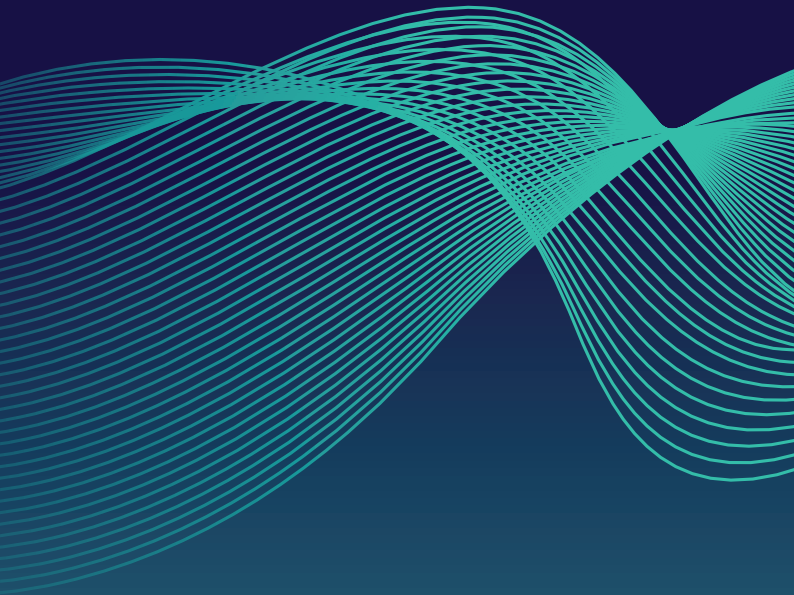

Manufacturer:

Arka Sp. z o.o.

ul. Ogrodowa 5, 76-004 Sianów, Poland

Phone: +48 94 341 77 19

arka-instalacje.pl